

DAS Departamento de Automação e Sistemas
CTC **Centro Tecnológico**
UFSC Universidade Federal de Santa Catarina

Generator efficiency for power management optimization

Report Submitted to Federal University of Santa Catarina

as a requirement to approval in subject:

DAS 5501: Internship in Control and Automation Engineering

Renan Marchini Rodrigues

Rüsselsheim, January/2013

Generator efficiency for power management optimization

Renan Marchini Rodrigues

Supervisors:

Dirk Balzer, Dr.-Ing.

Supervisor Signature

Nestor Roqueiro, Prof.Dr.

Supervisor Signature

This report was judged in the context of the discipline
DAS 5501: Internship in Control and Automation Engineering
and approved in its final version by
Course of Control and Automation Engineering

Abstract

With the necessity of the world to reduce the CO₂ emission on the atmosphere, all the countries are creating policies to achieve low emissions. In the EU, after 2020, all the cars produced with emissions more than 95g/km, the manufacturer will have to pay 95 for each gram above this limit, so this is an important issue for the company.

In GM Hybrids department is being developed this project to help the vehicle to emit less CO₂ in the atmosphere by charging the battery based on the efficiency of the generator, charging the battery when the efficiency is high to compensate it when the efficiency is low. But to have this efficiency, it is necessary to have the current and the temperature of the generator, which are not present on the CAN bus of the vehicle, so this two signals must be estimated without any extra sensors.

And this project describes estimation of one of this needed signals for the efficiency, the generator temperature: sensor calibrations, measurement plans, executed tests, results taken from the measurements, conclusions about the major influences involved on the generator temperature, the model done in MATLAB/Simulink from the results taken and the perspectives for the continuation of the project.

For the estimation of the temperature was defined 6 major influences on the generator inside temperature but in this project only 3 had enough time to be tested, analysed and added to the model, so the project could not have an accurate conclusion as desired. But even with more tests to be done and added in the model, could show some good results in some intervals of measurement and provide conclusions and discoveries about the signals and the car that was not known before. So this was a good step for the desired estimation of the temperature and consequently for the efficiency dependent way of charging.

Contents

| | |
|------------------------------------|-----------|
| List of Figures | 1 |
| 1 Introduction | 2 |
| 2 Project description | 3 |
| 3 Data Acquisition | 7 |
| 3.1 Hardware | 7 |
| 3.1.1 dSPACE Box | 7 |
| 3.1.2 Temperature sensor | 7 |
| 3.1.2.1 Description | 7 |
| 3.1.2.2 Calibration | 8 |
| 3.1.3 Current sensor | 9 |
| 3.1.3.1 Description | 9 |
| 3.1.3.2 Calibration | 10 |
| 3.2 Software | 12 |
| 3.2.1 dSPACE | 12 |
| 3.2.2 MATLAB/Simulink | 14 |
| 4 Temperature Estimation | 16 |
| 4.1 Measurement plan | 16 |
| 4.1.1 Purpose | 16 |
| 4.1.2 Strategy | 16 |
| 4.1.3 Major Influences | 16 |
| 4.1.4 Initial Plan | 17 |

| | | |
|---------|--------------------------------------|----|
| 4.1.4.1 | Generator Current | 17 |
| 4.1.4.2 | Generator Speed | 18 |
| 4.1.4.3 | Coolant Temperature | 18 |
| 4.1.4.4 | DPF Temperature | 19 |
| 4.1.4.5 | Outside Air Temperature | 20 |
| 4.1.4.6 | Airflow Influence | 21 |
| 4.1.5 | Executed Plan | 22 |
| 4.1.5.1 | Generator Current | 22 |
| 4.1.5.2 | Generator Speed | 22 |
| 4.1.5.3 | Coolant Temperature | 22 |
| 4.1.5.4 | DPF Temperature | 23 |
| 4.1.5.5 | Outside Air Temperature | 23 |
| 4.1.5.6 | Airflow Influence | 23 |
| 4.2 | Tests | 24 |
| 4.2.1 | Engine coolant temperature | 24 |
| 4.2.2 | Generator current | 25 |
| 4.2.3 | Generator speed | 27 |
| 4.2.4 | Time of cooling | 28 |
| 4.3 | Results | 30 |
| 4.3.1 | Modeling the dynamics of the systems | 30 |
| 4.3.2 | MATLAB/Simulink model implementation | 33 |
| 4.3.2.1 | Temperature Estimation Main Model | 33 |
| 4.3.2.2 | Coolant Temperature Influence | 35 |
| 4.3.2.3 | Generator Current Influence | 38 |
| 4.3.2.4 | Generator Speed Influence | 42 |
| 4.3.3 | Validation | 44 |

| | |
|----------------------------|-----------|
| 4.4 Perspectives | 46 |
| 5 Conclusion | 47 |
| References | 49 |

List of Figures

| | | |
|------|---|----|
| 2.1 | OPEL Astra GTC 1.7 Diesel | 3 |
| 2.2 | Major influences on generator inside temperature | 3 |
| 2.3 | Interdependency between the major influence signals | 5 |
| 2.4 | Expected model for the temperature estimation | 5 |
| 3.1 | Full Range Centigrade Temperature Sensor | 8 |
| 3.2 | dSPACE pins connected with the temperature sensors | 9 |
| 3.3 | CANshunt current sensor connection | 10 |
| 3.4 | CANshunt configuration window | 11 |
| 3.5 | dSPACE signals interface | 12 |
| 3.6 | CAN bus signals | 14 |
| 3.7 | Current sensor signals | 15 |
| 3.8 | Temperature sensor signals | 15 |
| 4.1 | Generator Current P-diagram | 17 |
| 4.2 | Generator Speed P-diagram | 18 |
| 4.3 | Coolant Temperature P-diagram | 19 |
| 4.4 | DPF P-diagram | 19 |
| 4.5 | Outside Air Temperature P-diagram | 20 |
| 4.6 | Airflow Influence P-diagram | 21 |
| 4.7 | Coolant temperature test 1 | 24 |
| 4.8 | Coolant temperature test 2 | 24 |
| 4.9 | Current test - step 100A | 25 |
| 4.10 | Current test - step 50A-100A | 26 |
| 4.11 | Current test - step 100A-25A-60A-25A | 26 |

| | |
|---|----|
| 4.12 Current test - AC ON in different initial conditions | 27 |
| 4.13 Current test - repeated current test in different initial conditions | 27 |
| 4.14 Generator speed test - 4 steps of speed | 27 |
| 4.15 Generator speed test - 3 different tests compared | 28 |
| 4.16 Time to cool the generator inside temperature | 28 |
| 4.17 Hammerstein-Wiener structure | 32 |
| 4.18 Temperature Estimation Main Model | 33 |
| 4.19 Coolant Temperature Influence Model | 35 |
| 4.20 All the tests of coolant temperature influence together | 36 |
| 4.21 Disturbance caused by the engine fan after the coolant reaches 100°C | 37 |
| 4.22 Generator Current Influence Model | 38 |
| 4.23 Step response of the transfer functions of the current influence | 39 |
| 4.24 Different outputs of temperature for the same input of current | 40 |
| 4.25 Generator Speed Influence Model | 42 |
| 4.26 Labels indicating the colors on the validation graphics | 44 |
| 4.27 Validation 1 of the temperature estimation | 44 |
| 4.28 Validation 2 of the temperature estimation | 44 |
| 4.29 Validation of the temperature estimation in a real case test | 45 |

Capítulo 1: Introduction

In order to reduce the CO₂ emission, it is desirable to develop an efficiency dependent way of charging the battery, which is dependent to the efficiency of the generator. And to make this possible, it is necessary to have mainly 2 major influences on the generator to determine its efficiency: inside temperature and current.

But the problem is, that the CAN bus of the car doesn't provide those signals in it, so it would be necessary to estimate them to perform this function. And besides that, it has another issue: this estimation must be done just with the signals already present on the car (engine coolant temperature, engine speed, outside air temperature, diesel particulate filter, vehicle speed, etc) without any extra sensors to be installed on the assembly line to avoid extra costs of production.

So the project was divided in 2 major parts: the generator inside temperature estimation and the generator current estimation. And here it will be discussed just the temperature estimation of the generator.

After these estimations are done and validated, it will be possible to develop an algorithm to make the efficiency dependent way of charging the battery to be used on the car and this way achieve the biggest goal desired after all: reduce CO₂ emission to help the company to accomplish the goal of not emitting more than 95 grams of CO₂ in the MVEG test after 2020, because each gram more than that will be punished by 95 euros. So this is an important issue for the company to be developed .

Capítulo 2: Project description

To estimate the inside temperature of the generator, it was used in this project an OPEL Astra GTC 1.7 diesel for the tests and validation, as we can see in Figure 2.1:



Figure 2.1: OPEL Astra GTC 1.7 Diesel

In Figure 2.2, we can see in green color, all the signals we have on CAN bus that makes influence on the generator temperature. All these signals, considered major influences for this estimation, will be tested to observe how each one contributes for the final estimation of the inside temperature of the generator.

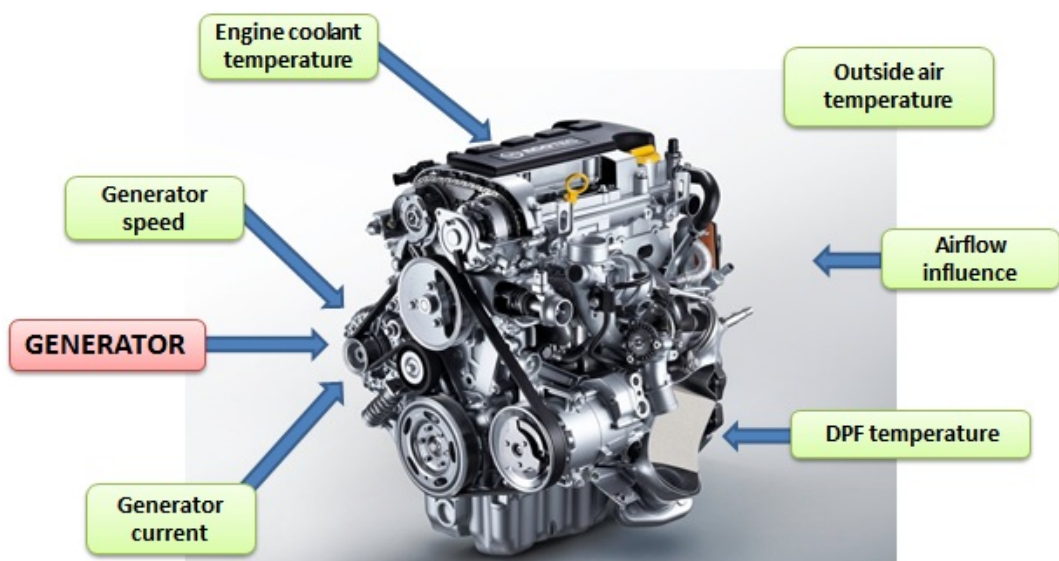

Figure 2.2: Major influences on generator inside temperature

So for this system, we consider 6 subsystem for the temperature estimation:

- **ENGINE COOLANT TEMPERATURE:** signal that corresponds to the temperature of the fluid that cools down the engine and because of the proximity of the generator and the engine as we can see on Figure 2.2 it is considered a major influence. Interdependency with the major influences: Engine coolant temperature = function(airflow influence, outside air temperature, generator speed)
- **GENERATOR CURRENT:** the generator is responsible to charge the battery and also supply the car loads in some cases. This way the current inside it is always changing and this variation is also considered a major influence on the temperature of the generator. Interdependency with the major influences: Generator current = function(airflow)
- **GENERATOR SPEED:** the speed of the generator is around 2,6 times the speed of the engine. As higher the speed, as higher is expected to be the generator temperature, so it is also a major influence. Interdependency with the major influences: none
- **OUTSIDE AIR TEMPERATURE:** if the car is in an environment with 40°C or -5°C the temperature of the generator is expected to change differently, and for this reason we will observe it as a major influence for the temperature estimation. Interdependency with the major influences: none
- **AIRFLOW INFLUENCE:** the engine fan speed combined with the vehicle speed, produces an airflow through the hood of the car and it cools down the temperature of the generator, so it will also be tested as a major influence. Interdependency with the major influences: Airflow influence = function(generator speed, engine coolant temperature)
- **DIESEL PARTICULATE FILTER(DPF) TEMPERATURE:** as we can see in Figure 2.2, the DPF is close to the generator and when it burns the diesel particles, it produces very high temperature around it and for this reason is considered a major influence. Interdependency with the major influences: none

The table shown on Figure 2.3 shows better these interdependency:

| VARIABLE: | EFFECTS: | |
|----------------------------|-----------------------|---------------------|
| ↑ Airflow influence: | ↓ Coolant temperature | ↑ Generator current |
| ↑ Generator speed: | ↑ Coolant temperature | ↑ Airflow influence |
| ↑ Outside air temperature: | ↑ Coolant temperature | |
| ↑ Coolant temperature: | ↑ Airflow influence | |
| ↑ Generator current: | none | |
| ↑ DPF temperature: | none | |

Figure 2.3: Interdependency between the major influence signals

Figure 2.4 can show the idea of the algorithm expected: with the planned tests, it will be developed the transfer functions(TF) on the frequency domain of each subsystem(coolant temperature, generator current, generator speed, outside air temperature, airflow influence, Diesel Particulate Filter temperature), which will simulate the influence of each signal in the final estimation of the generator temperature. This way, putting in the input of this transfer functions the corresponding major influence signal and summing all of the outputs of these transfer functions, we will obtain the desired temperature estimation.

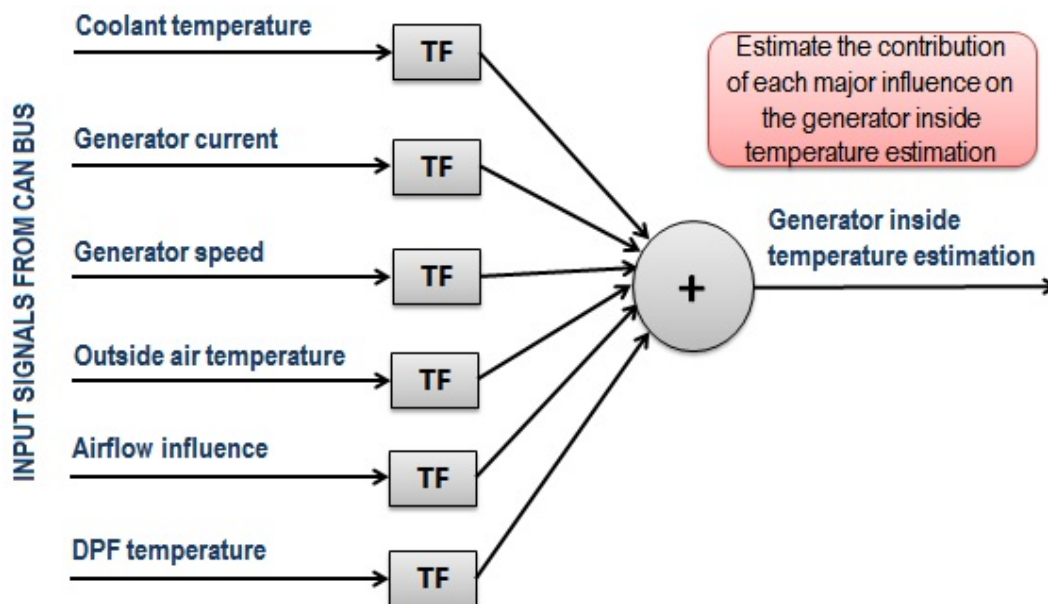

Figure 2.4: Expected model for the temperature estimation

So the goal of this project is to develop the tests for all the major influences signals to model the behavior of each one to obtain the contribution of them for the desired generator inside temperature.

The first approach for this problem will be doing the modeling with the step response test, trying a linear solution which is more practical and simple. The idea is to model the system in many different points of operation and have a different transfer function for each interval. This idea intends to minimize the possible non linearities or differences on the dynamics of the system in the whole range of measurement of the signals. If this solution is not accurate enough, another techniques will be applied such as for multivariable or non-linear systems.

Capítulo 3: Data Acquisition

3.1: Hardware

3.1.1: dSPACE Box

To measure and control the data in this project, an embedded controller is used on the car called dSPACE MicroAutoBox II 1401/1501, which is a real-time system for performing fast function prototyping in fullpass and bypass scenarios. It operates without user intervention and it is capable to run MATLAB/Simulink compiled models to perform the algorithms to read the signals from High Speed CAN bus and calculate the desired results for the project.

3.1.2: Temperature sensor

Two LM35-DZ analog temperature sensors were used to measure the temperature of the generator: one inside and one outside. The data from the inside temperature sensor was used to do the model and the validation of the generator's temperature estimation and the outside temperature sensor was used to observe the influence of the environment on the generator temperature.

3.1.2.1: Description

The LM35 series are precision integrated-circuit temperature sensors, whose output voltage is linearly proportional to the Celsius (Centigrade) temperature. The LM35 thus has an advantage over linear temperature sensors calibrated in ° Kelvin, as the user is not required to subtract a large constant voltage from its output to obtain convenient Centigrade scaling. It does not require any external calibration or trimming to provide typical accuracies of 0.25°C at room temperature and 0.75°C over a full -55 to +150°C temperature range. Low cost is assured by trimming and calibration at the wafer level. Its low output impedance, linear output, and precise inherent calibration make interfacing to readout or control circuitry especially easy. It can be used with single power supplies, or with plus and minus supplies. As it draws only 60 uA from its supply, it has very low self-heating, less than 0.1°C in still air. The LM35 is rated to operate over a -55° to +150°C temperature range and has the following features:

- Calibrated directly in ° Celsius (Centigrade);

- Linear + 10.0 mV/°C scale factor;
- 0.5°C accuracy guaranteeable (at +25°C);
- Rated for full -55° to +150°C range;
- Suitable for remote applications;
- Low cost due to wafer-level trimming;
- Operates from 4 to 30 volts;
- Less than 60 uA current drain;
- Low self-heating, 0.08°C in still air;
- Nonlinearity only 0.25°C typical;
- Low impedance output, 0.1 W for 1 mA load

3.1.2.2: Calibration

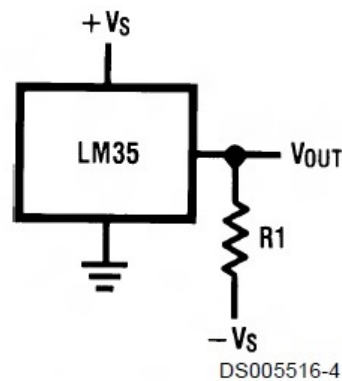

$$\begin{aligned} \text{Choose } R_1 &= -V_S/50 \mu\text{A} \\ V_{\text{OUT}} &= +1,500 \text{ mV at } +150^\circ\text{C} \\ &= +250 \text{ mV at } +25^\circ\text{C} \\ &= -550 \text{ mV at } -55^\circ\text{C} \end{aligned}$$

Figure 3.1: Full Range Centigrade Temperature Sensor

On the V_S wire, it was used the 5V power supply from dSPACE, so our chosen R_1 resistor was of 100k Ω . This way, the V_{out} wire, shown on the figure 3.1, with our temperature measurement was connected on dSPACE analog input as shown on the picture 3.2:

Pinout

The following illustration shows the pin numbering of the I/O connector (rear view of MicroAutoBox):

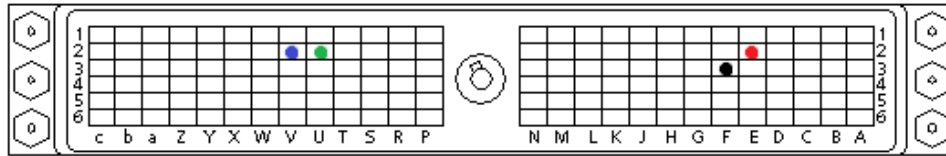

Figure 3.2: dSPACE pins connected with the temperature sensors

The connections made on the dSPACE box for the temperature sensors are related on the picture 3.2 this way:

- Power supply: red dot on the picture, connected at the VSENS pin in the position E2 of dSPACE box.
- Ground: black dot on the picture, connected on the GND pin in the position V2 of dSPACE box.
- Inside temperature sensor: green dot on the picture, connected on the 'ADC Type 1 Con 4 Ch4' of dSPACE box.
- Outside temperature sensor: blue dot on the picture, connected on the 'ADC Type 1 Con 3 Ch4' of dSPACE box.

3.1.3: Current sensor

To measure the generator current to be used on the tests and the validation of the generator's temperature estimation, a CANshunt current sensor was used.

3.1.3.1: Description

This sensor measures currents of up to 750A with a resolution of 3 mA and has the following features:

- High-speed CAN interface;
- CAN-capable shunt;
- Current measurement range: -750 A to +750 A;
- Automotive measuring ranges: 70 A, 150 A and 750 A;

- Resolution: 1 mA in 70 A range, 2 mA in 150 A range, and 10 mA in 750 A range;
- Voltage measuring range: 6 to 20 V;
- Compensation for thermoelectric voltages;
- Current measurement accuracy: 0.5% of the measured value;
- Temperature range: -40 to +85 °C;
- Supply voltage: +4 to +36 V;
- Case (L/W/H): 94 x 39 x 49 mm;
- Weight: approx. 500 g;
- Enclosure rated IP65;

3.1.3.2: Calibration

This sensor is attached on the generator cable that supplies current for the battery as shown in the picture below:

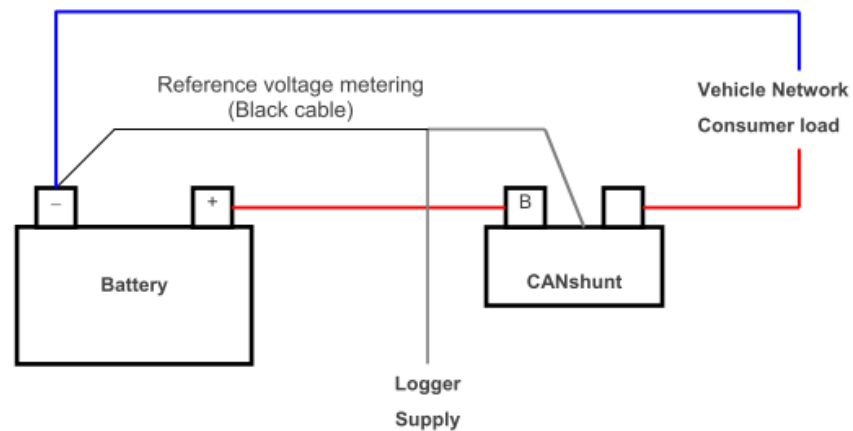

3.1 Connection for the CANlog 3/4 or ISCan II data logger

The connection for the CANlog 3/4 or ISCan II data logger is as follows:

| Pin | Colour | Meaning |
|----------|--------|-------------------------|
| 1 to 13 | | not used |
| 14 | white | +4 — 36 V _{DC} |
| 15 | yellow | CAN_H |
| 16 | green | CAN_L |
| 17 to 21 | | not used |
| 22 | brown | GND |
| 23 to 25 | | not used |

25-pin D-sub male connector

Figure 3.3: CANshunt current sensor connection

With the CANshunt configuration CD in the windows shown in the picture 3.4, the signal from the sensor was configured in Modus 5 to send the data to the High Speed CAN bus on the identifier 0x23. This way it was possible to get this signal from MATLAB/dSPACE software to use on the tests and validation of the temperature estimation.

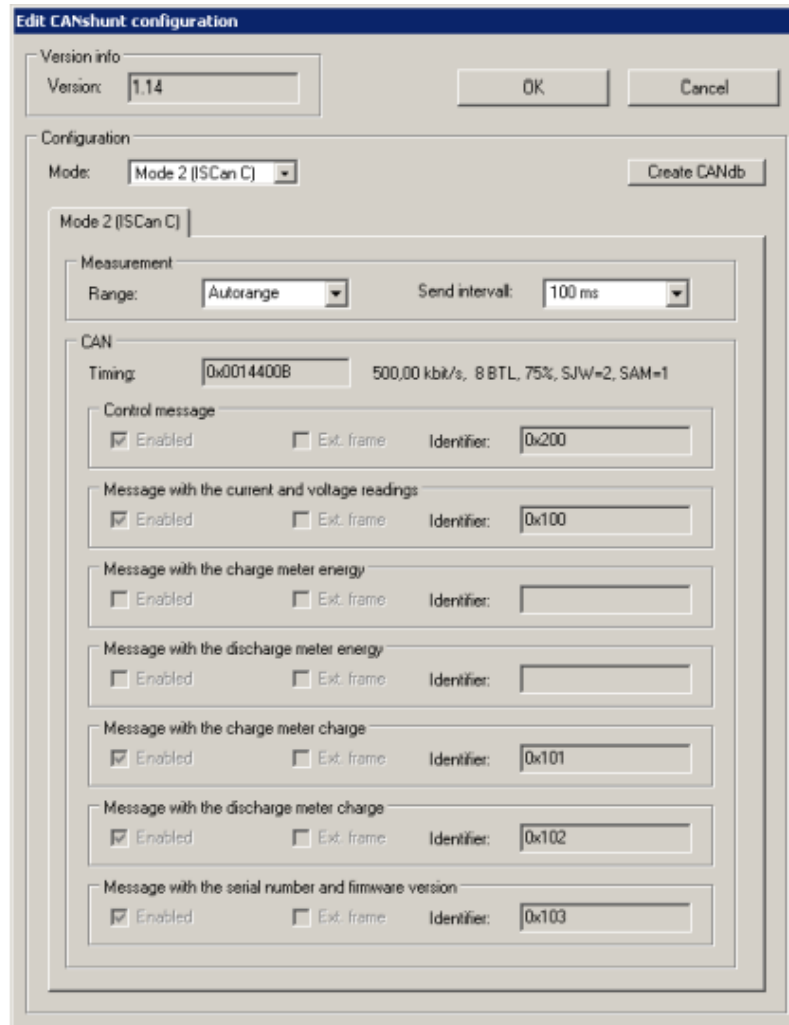

Figure 3.4: CANshunt configuration window

3.2: Software

3.2.1: dSPACE

This interface on dSPACE was developed to read the signals from the High Speed and Low Speed CAN bus and show it on this screen shown below for recording and analysis of the data:

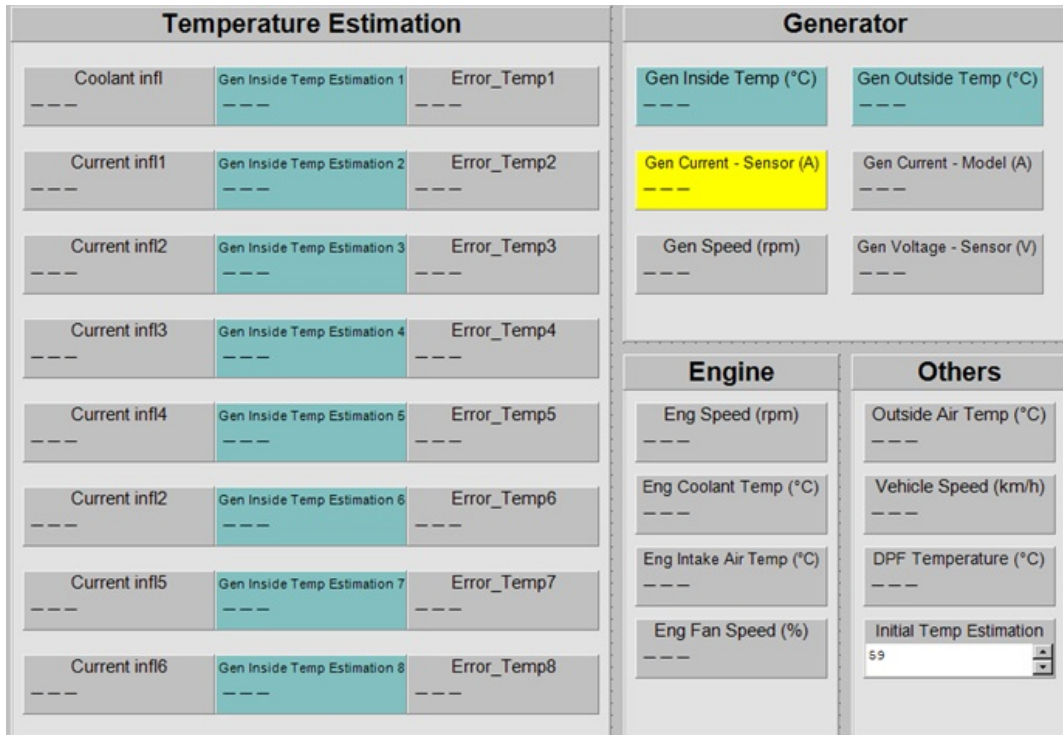

Figure 3.5: dSPACE signals interface

- **Temperature Estimation Box:**

The signals in this place are taken from the CAN bus but after the calculation on the MATLAB/Simulink model. In the first column the different approaches of major influence (coolant and current) in the temperature estimation are shown, which will be better detailed in the next chapter. The second column, in green color, is the final temperature estimation calculated on the model and the third column is the error, which is the difference between the current generator inside temperature and the estimation calculated on the model. Each line on this box corresponds to a different approach of estimation.

- **Generator Box:**

The signals in this place are taken directly from the CAN bus and are shown below:

- Generator Inside Temperature(1st line, 1st column): temperature sensor placed inside the generator.
- Generator Outside Temperature(1st line, 2nd column): temperature sensor placed outside the generator.
- Generator Current - Sensor(2nd line, 1st column): current sensor placed on the generator power supply.
- Generator Current - Model(2nd line, 2nd column): current estimated on the model made in another project.
- Generator Speed(3rd line, 1st column);
- Generator Voltage - Sensor(3rd line, 2nd column): voltage taken from the current sensor.

- **Engine Box:**

The signals in this place are taken directly from the CAN bus and are shown below:

- Engine Speed;
- Engine Coolant Temperature;
- Engine Intake Air Temperature;
- Engine Fan Speed;

- **Others Box:**

The signals in this place are taken directly from the CAN bus and are shown below:

- Outside Air Temperature;
- Vehicle Speed;
- DPF Temperature;
- Initial Temperature Estimation: initial condition of the generator to put and be used on the temperature estimation, because it was not possible until now to guess this initial condition in different real cases.

3.2.2: MATLAB/Simulink

This software take the signals from the CAN bus of the car, process them accordingly to the model logic and send the calculated signals back to the CAN bus, this way dSPACE is able to use this signals for the measurements.

The pictures 3.6, 3.7 and 3.8 show the blocks of the model responsible to get the signals from the sensors and the CAN bus to be used on the MATLAB/Simulink model. The other signals, those calculated, will be shown and explained on the next chapter to detail the temperature estimation model.

The figure 3.6 shows the blocks that takes all the signals from the CAN bus that are used on the algorithm: IBS Data, High Speed CAN Data, Low Speed CAN Data and ECM Data:

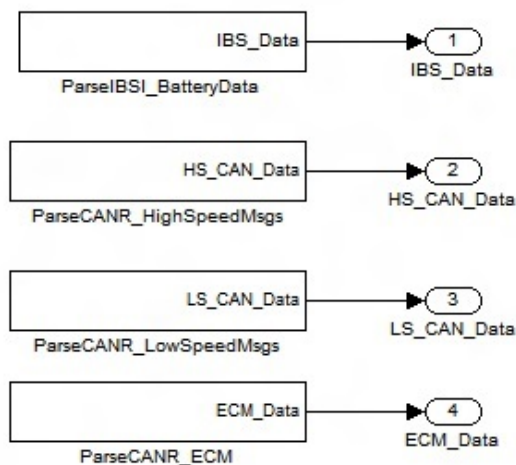

Figure 3.6: CAN bus signals

The figure 3.7 shows the block that receive the data from the current sensor, pass through a system that takes the last 100 values of measurement and gives out the average (because the oscillation of the values are very high) and divide this value by 1000 to give the value of the current in Amperes and the voltage in Volts:

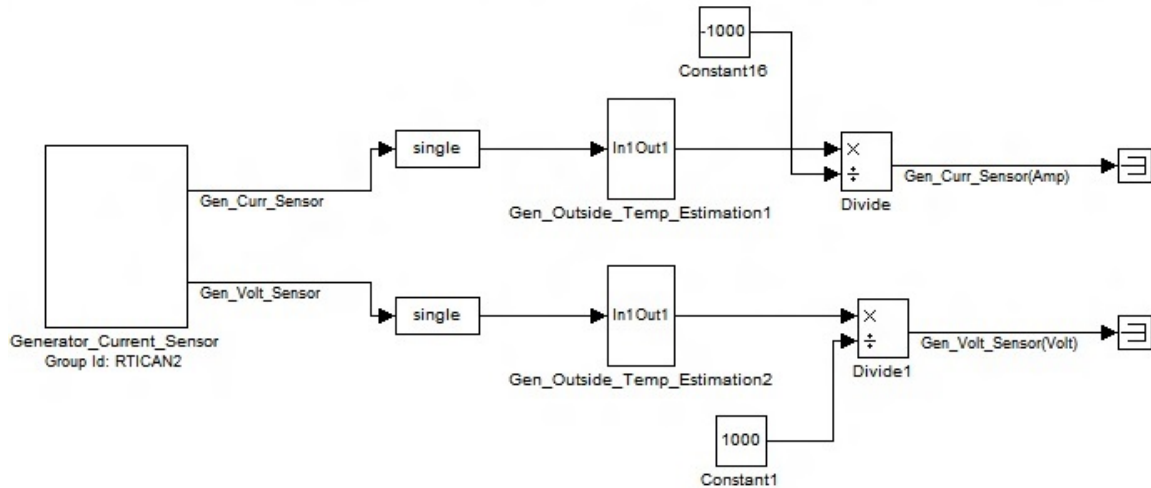

Figure 3.7: Current sensor signals

The figure 3.8 shows the block of the algorithm that does the same thing as described for the current sensor signal, but in this case it gives the value of measurement of the inside and of the outside temperature of the generator:

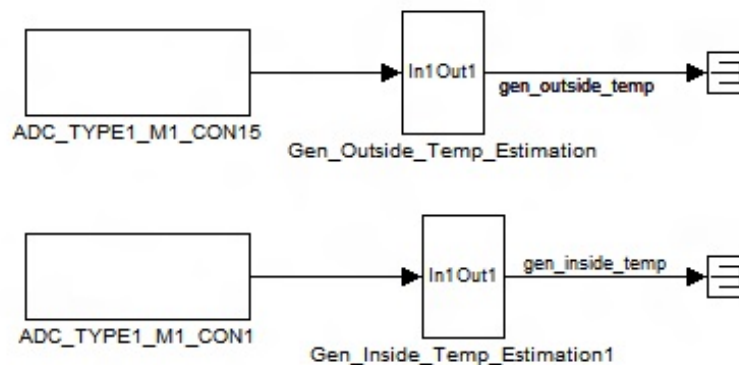

Figure 3.8: Temperature sensor signals

Capítulo 4: Temperature Estimation

In this chapter will be shown all the steps planned, executed and still needed to do the estimation of the generator temperature.

4.1: Measurement plan

4.1.1: Purpose

This procedure intends to obtain indirectly the generator's temperature, in other words, to have the temperature of the generator without any extra sensor installed on the car. This estimation will consider all the major influences on the generator's temperature to create a logic to obtain an accurate generator's temperature estimation.

4.1.2: Strategy

1 - Measure the generator's temperature directly with sensors(LM35DZ) via dSPACE and use it as reference.

2 - Measure one major influence(shown below) per time and make all the others constant to see how each one affects the generator's temperature(create graphic, table or algorithm).

3 - Compare and establish a relation between each major influence and the generator's temperature for the final estimation.

4.1.3: Major Influences

The signals below will be observed and tested as the main influences on generator's temperature:

- Generator Current
- Generator Speed
- Coolant Temperature

- Diesel Particulate Filter(DPF) Temperature
- Outside Air Temperature
- Airflow influence

4.1.4: Initial Plan

In this section is described the initial plan discussed to do good tests to estimate the temperature. Some of this things were changed during the tests and will be described on the next section.

4.1.4.1: Generator Current

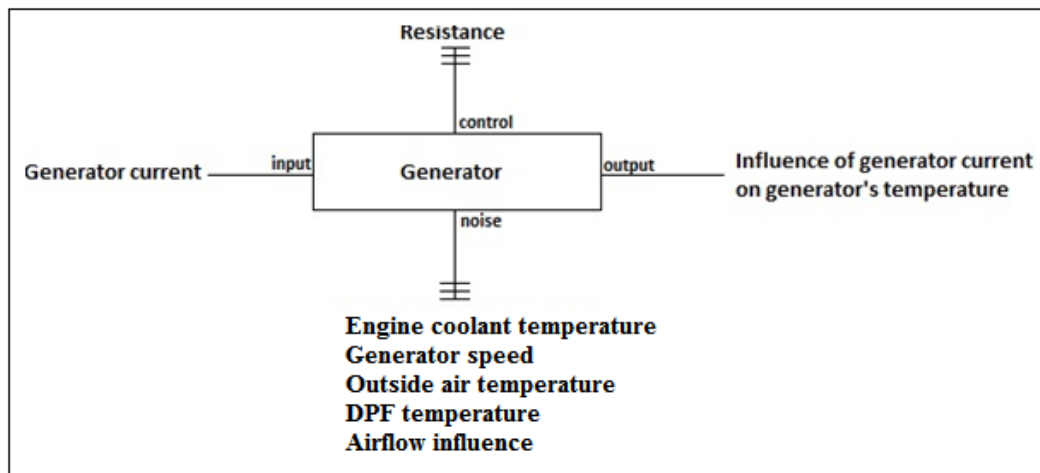

Figure 4.1: Generator Current P-diagram

- Conditions:
 - Engine in idle
 - Coolant in operation point
 - No DPF burn
 - Outside air temperature constant
 - AC ON
- Test:

With the external resistor, put the generator current on this steps: 10A, 40A, 70A, 100A, 130A. Waiting 15 minutes on each step to reach the steady state.

- Duration:

To cover the 5 steps waiting 15 minutes on each one, this test will take 75 min.

4.1.4.2: Generator Speed

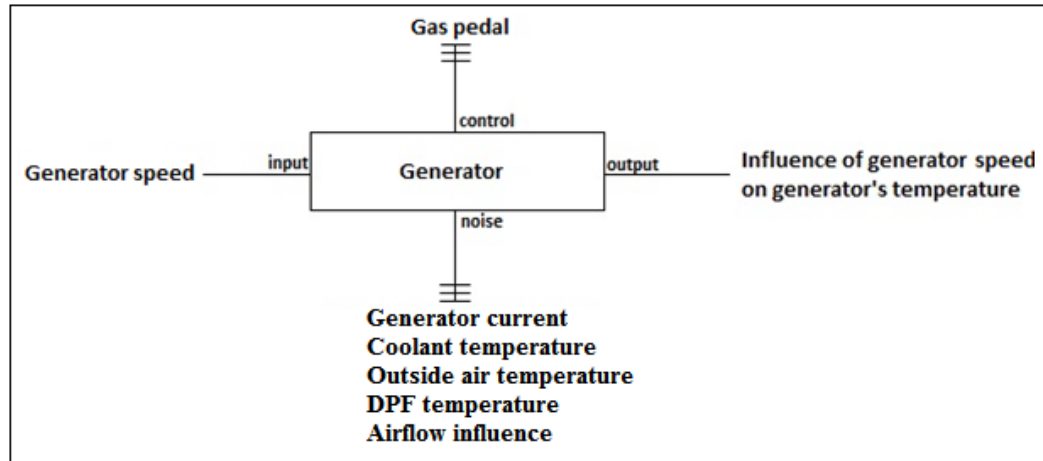

Figure 4.2: Generator Speed P-diagram

- Conditions:

- Detach the generator from the car's circuit
- Coolant in operation point
- No DPF burn
- Outside air temperature constant
- AC ON

- Test:

Pressing the gas pedal, put the generator speed on this steps: 1500 rpm, 3500 rpm, 5500 rpm, 7500 rpm, 9500 rpm. Waiting 15 minutes on each step to reach the steady state.

- Duration:

To cover the 5 steps waiting 15 minutes on each one, this test will take 75 min.

4.1.4.3: Coolant Temperature

- Conditions:

- Detach the generator from the car's circuit
- Engine in idle
- No DPF burn

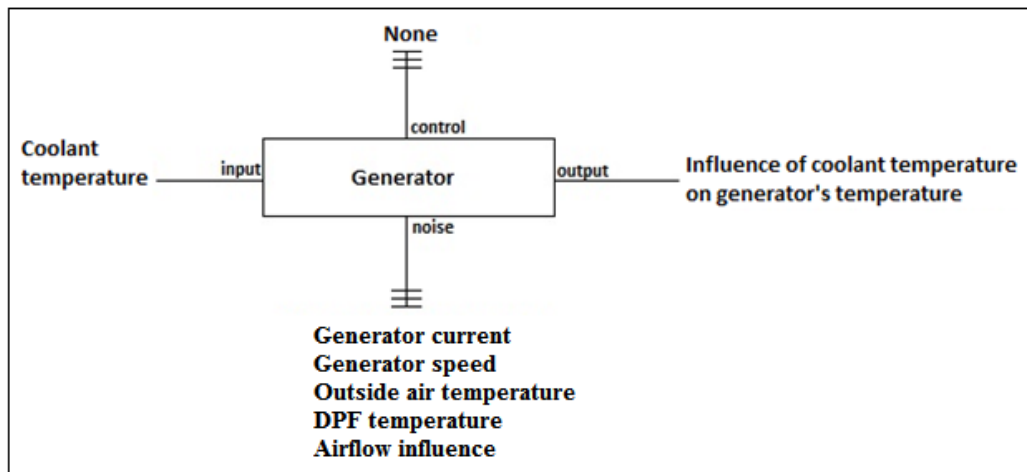

Figure 4.3: Coolant Temperature P-diagram

- Outside air temperature constant
- AC ON
- Test:

Observe the standart range of coolant temperature and see how it affects the generator's temperature in 5 different steps.
- Duration:

The time that the temperature stays in each point doesn't take so longer, so the duration of the test is the time of coolant rising temperature from OAT to the operation point.

4.1.4.4: DPF Temperature

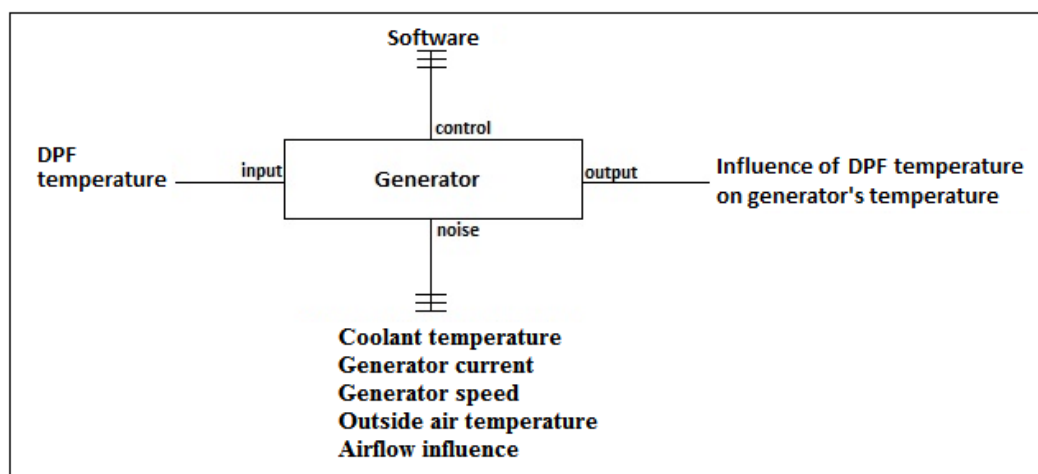

Figure 4.4: DPF P-diagram

- Conditions:
 - Detach the generator from the car's circuit
 - Engine in idle
 - Coolant in operation point
 - Outside air temperature constant
 - AC ON
- Test:

By software force DPF burn to observe how it affects generator's temperature.
- Duration:

Time of DPF Cycle.

4.1.4.5: Outside Air Temperature

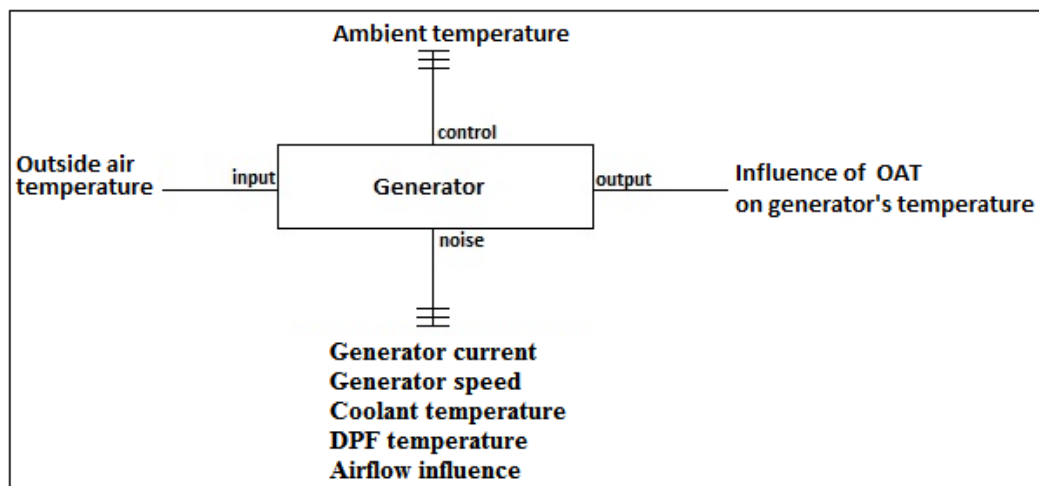

Figure 4.5: Outside Air Temperature P-diagram

- Conditions:
 - Detach the generator from the car's circuit
 - Engine in idle
 - Coolant in operation point
 - No DPF burn
 - AC ON
- Test:

In a climate room put the car in this 5 steps: -5°C, 0°C, 5°C, 10°C, 15°C, 20°C, 25°C.
Waiting 15 minutes on each step to reach the steady state.

- Duration:

To cover the 5 steps waiting 15 minutes on each one, this test will take 105 min.

4.1.4.6: Airflow Influence

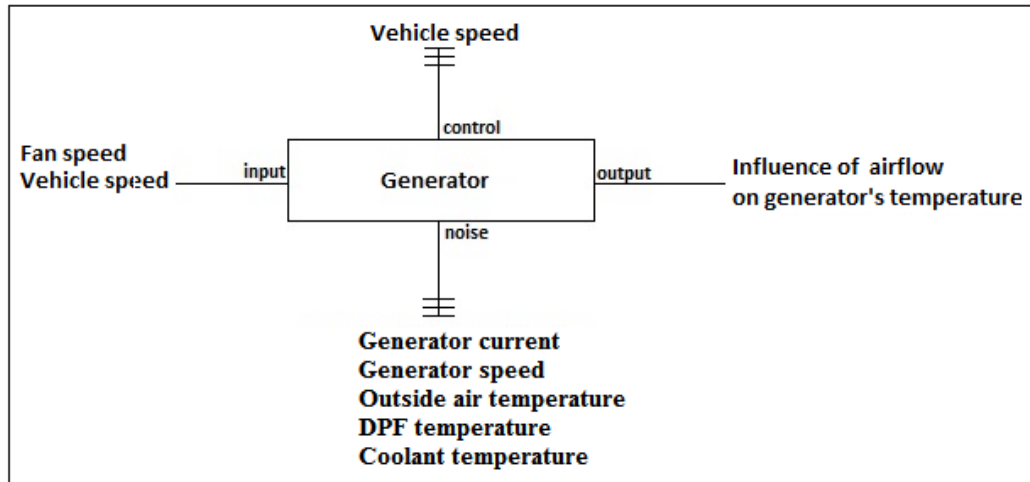

Figure 4.6: Airflow Influence P-diagram

- Conditions:

- Detach the generator from the car's circuit
- Engine in idle
- Coolant in operation point
- No DPF burn
- Outside air temperature constant
- AC ON

- Test:

After the engine is hot, keep all the conditions constant and apply steps of fan speed on the car in these 5 values: 25km/h, 50km/h, 75km/h, 100km/h and 125km/h and see how the generator temperature changes with these airflow through the car. Waiting 15 minutes on each step to reach the steady state.

- Duration:

To cover the 5 steps waiting 15 minutes on each one, this test will take 105 min.

4.1.5: Executed Plan

Here is described what happened in each test and the problems found during all of them. As a general observation, the time believed to be enough for the temperature reaches the steady state value in each step was not long enough, because the temperature has a very slow system response. This will be shown on the next section where all the tests are presented.

4.1.5.1: Generator Current

Besides the difficulty of holding the current generator in the desired value of the step planned because the car does not has constant loads and charging modes during all the time, we also did not have the generator current sensor integrated on the car since the beginning of the measurements, so we followed the generator current estimation made by another project to do some current tests in the beginning, but later we integrated the current sensor on the car and made other current tests. This test went well and we show the results shown later with the model made for this influence.

4.1.5.2: Generator Speed

This test was executed some times but it was really hard to separate the major influences on this test and analyze just the generator speed influence, because when you rise the engine speed (consequently the generator speed) the coolant temperature keeps rising and affecting the generator temperature. Besides that, the engine fan starts after the coolant reaches 100°C, so the disturbance on the generator was really big, adding peaks down during the ventilation and peaks up after the ventilation when the heat taken from the engine went off, rising the generator temperature this way.

So the strategy was to do this measurement on a bench to observe the speed influence only, and everything was done to do this test in time: the new sensors, the recorder, the measurement plan and all the other things needed, but we couldn't schedule a time on the bench because the year was in the end so this test was canceled in that time.

4.1.5.3: Coolant Temperature

This test was executed well and got many data to do the analysis. The results will be shown later with the model made for this influence.

4.1.5.4: **DPF Temperature**

The DPF signal was not found on the CAN bus, neither after many attempts in different ways to get it, so this test was canceled in that time. And since this influence doesn't happen everytime, it is considered just a big disturbance on the system and not a regular influence like the others, so it was not so important like the others for this time, and for this reason this test was postponed.

4.1.5.5: **Outside Air Temperature**

This test needed to be done on a climate room but it was not possible to get one. So some tests were made in the outside environment in different temperatures(sun, normal, snow) and got some data about this influence. But no specific test was done like initially planned.

4.1.5.6: **Airflow Influence**

The plan was to put the airflow speed in different steps, but it was not possible to get one controllable fan to do that because all of them were busy in the time on the dynos. So we took one constant speed fan to this test and could do some measurements about it, but not like the plan.

4.2: Tests

In this project a lot of tests were realized. Some of them are presented in the following section:

4.2.1: Engine coolant temperature

The pictures 4.7 and 4.8 show a coolant temperature test. The red curve is the coolant temperature and the green curve is the generator inside temperature:

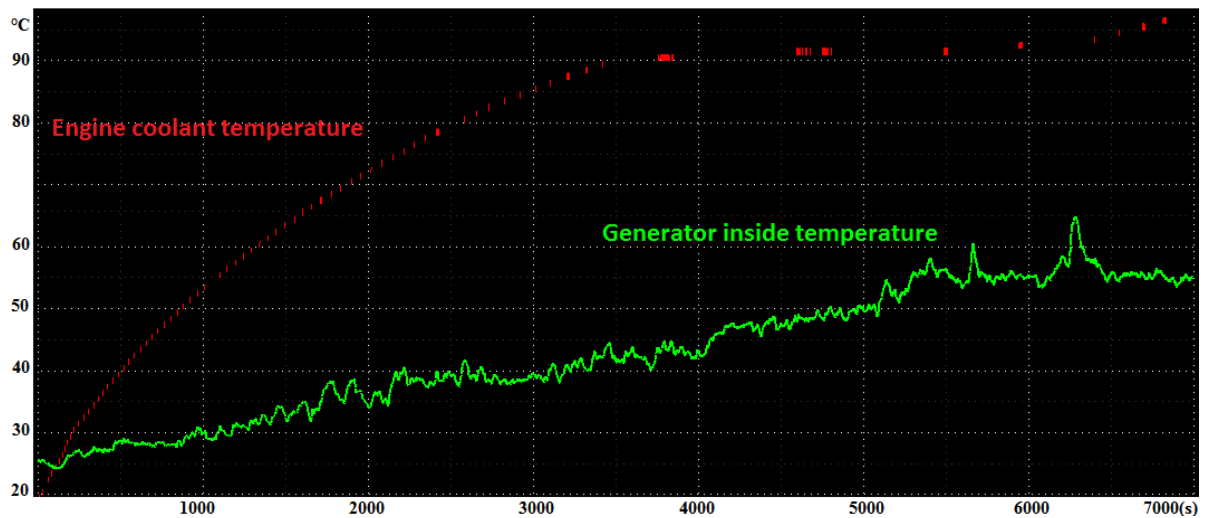

Figure 4.7: Coolant temperature test 1

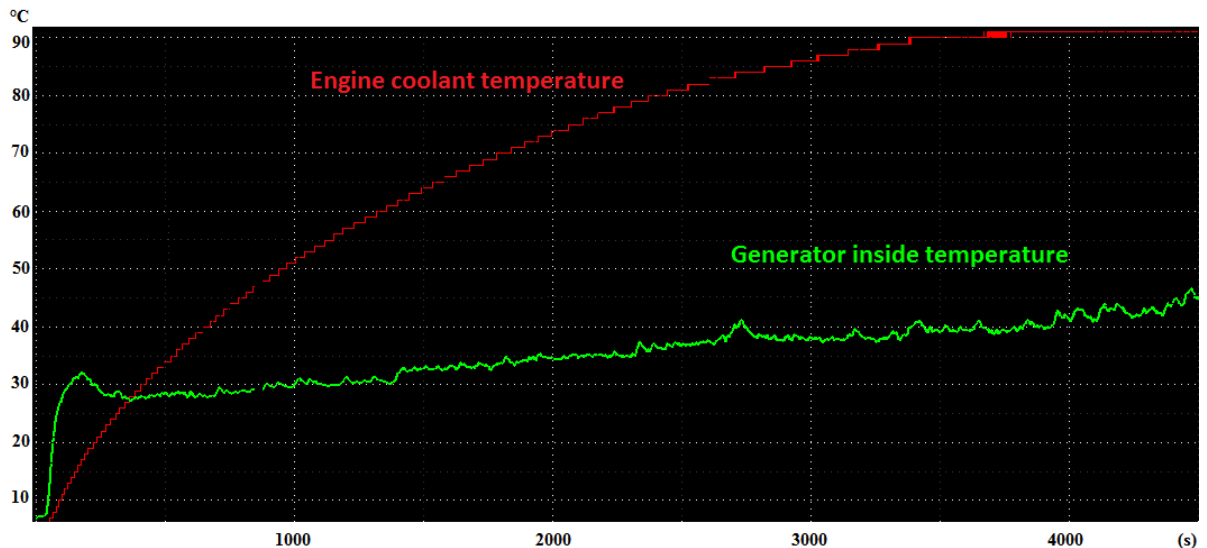

Figure 4.8: Coolant temperature test 2

We can see in both graphics the linear behavior of the generator inside temperature while the coolant temperature is rising. The behavior in the beginning of the generator temperature in the figure 4.8 occurred because of the initial current to start the car, this way the temperature

went up faster than the normal. After that disturbance, there's just the coolant influence on the generator inside temperature.

4.2.2: Generator current

The picture shows the generator in initial temperature as 20°C and applied a step of 100A of current on it, rising the temperature for around 90°C . The behavior of the output is similar to a first order system response. But we can note in the picture that, from around 3500s, the noise cause by the engine fan starts doing an up and down disturbance:

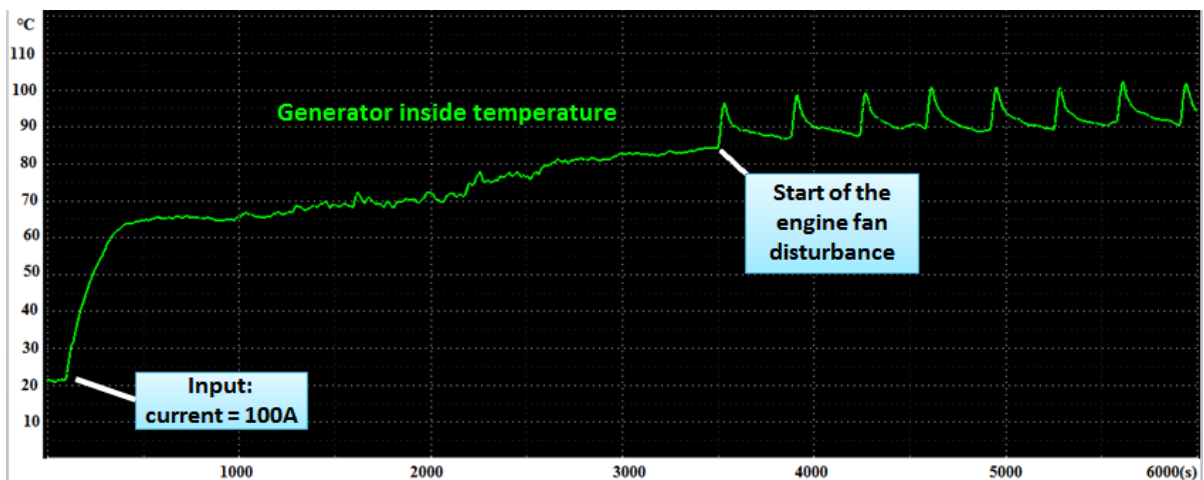

Figure 4.9: Current test - step 100A

The test of the figure 4.10, shows the generator inside temperature (green line) in 40°C as initial condition and at 0s, the generator current (red line) goes from 0 to 50A and stays this way until around 1000s, then after this, the current goes from 50A to 100A. The output of the generator is shown in the figure:

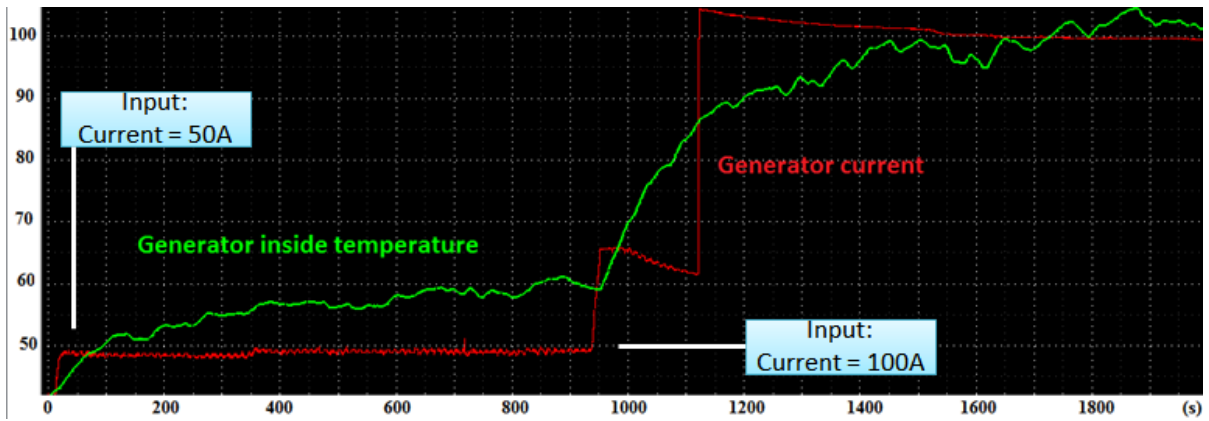

Figure 4.10: Current test - step 50A-100A

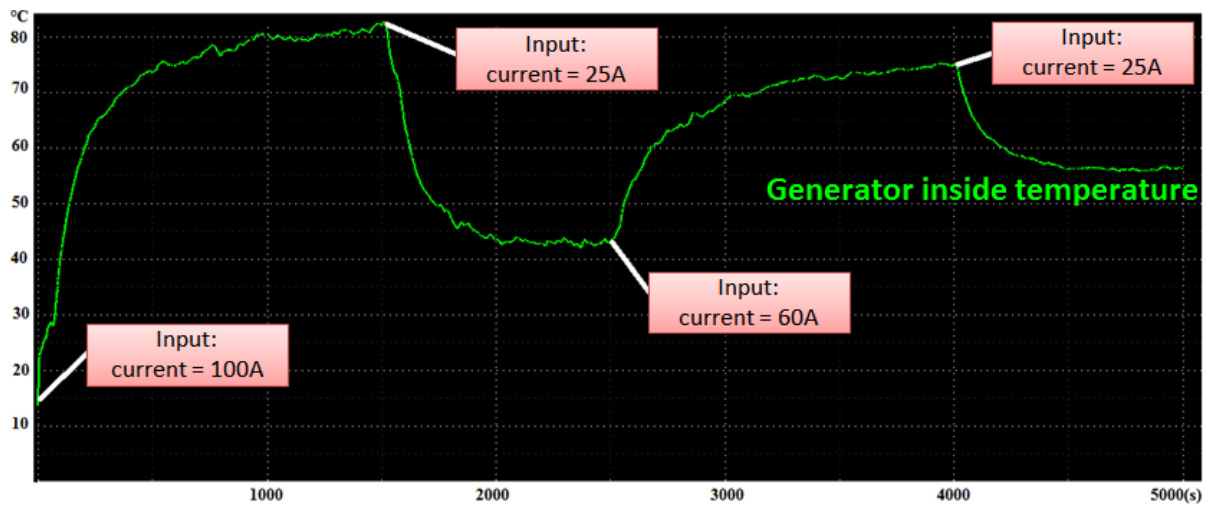

Figure 4.11: Current test - step 100A-25A-60A-25A

In this test of Figure 4.11 different values of current were applied on the generator to observe the behavior in these situations, and the conclusion is that the current has an offset response on the generator inside temperature: when the current rises to a certain value, the temperature also rises until a certain steady state value and when the current went down, the temperature also went down until a constant value.

The problem found in this situation, as mentioned, is to define this gain in consequence of the current change, because this is not a linear system and the same variation on the current may not produce the same change on the temperature, as showed on the figures 4.12 and 4.13 below where the same input was applied on the generator but in different initial conditions. The curve in green is one measurement and the red curve is the other one in these two figures:

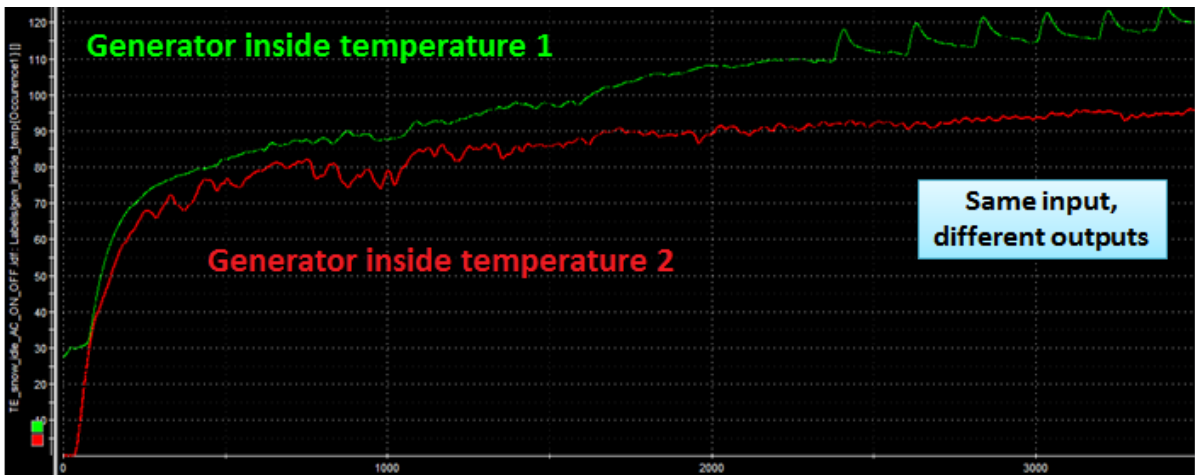

Figure 4.12: Current test - AC ON in different initial conditions



Figure 4.13: Current test - repeated current test in different initial conditions

4.2.3: Generator speed

As mentioned, no big conclusion could be done from this test, but Figures 4.14 and 4.15 show two graphics from this kind of measurement. In Figure 4.14, the green curve is the generator speed and the red curve is the temperature measurement:

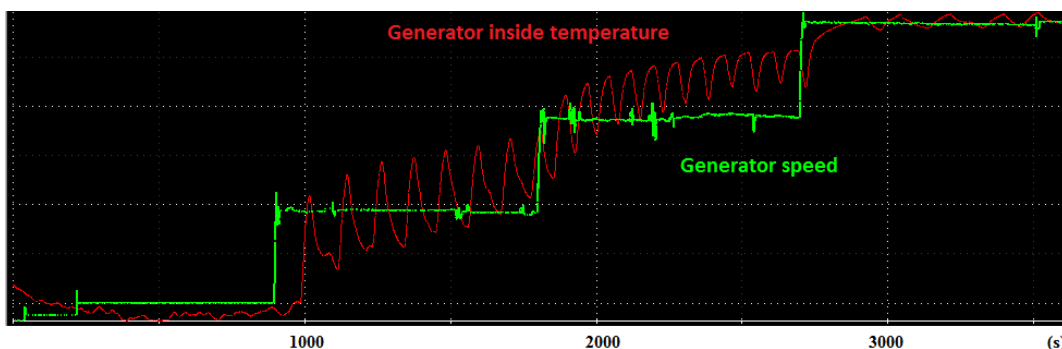

Figure 4.14: Generator speed test - 4 steps of speed

Figure 4.15 show 3 generator inside temperature measurements in 3 different speeds of the generator, as described on it:

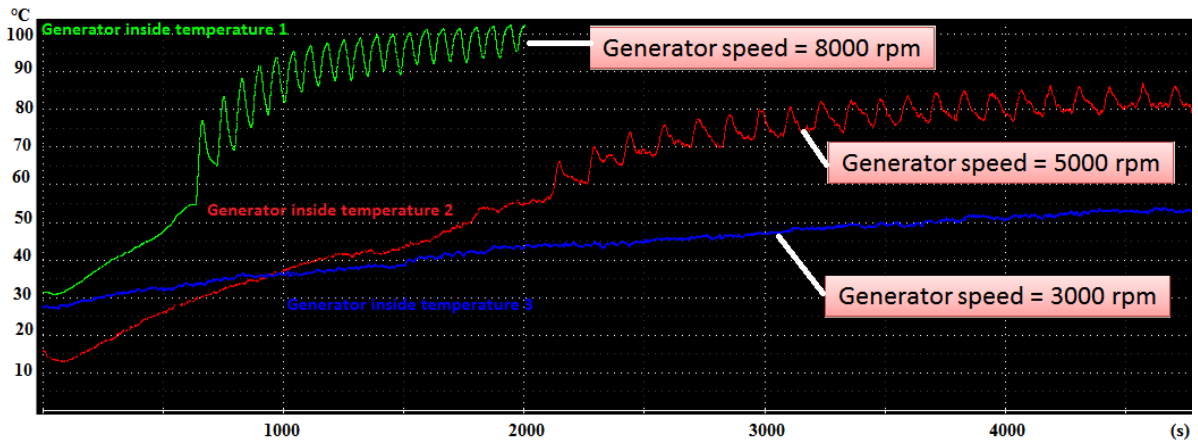

Figure 4.15: Generator speed test - 3 different tests compared

4.2.4: Time of cooling

One of the detected problems was how to determine the initial temperature of the generator when the measurement starts. Because if the measurement starts after a long time when the car is turned off, the inside temperature is equal to the outside air temperature, but if the car is heated and stays just some minutes turned off, we don't have any signal recording this current temperature of the generator to be used as a initial condition on the next estimation.

This way, it was thought to do some tests to see how the temperature of the generator cools down when the car is turned off in order to have some model of this to estimate this temperature to be used as initial condition. Figure 4.16 shows a 6000s measurement with the car turned off after the engine is heated, and the temperature went from 100°C to 40°C in this interval.

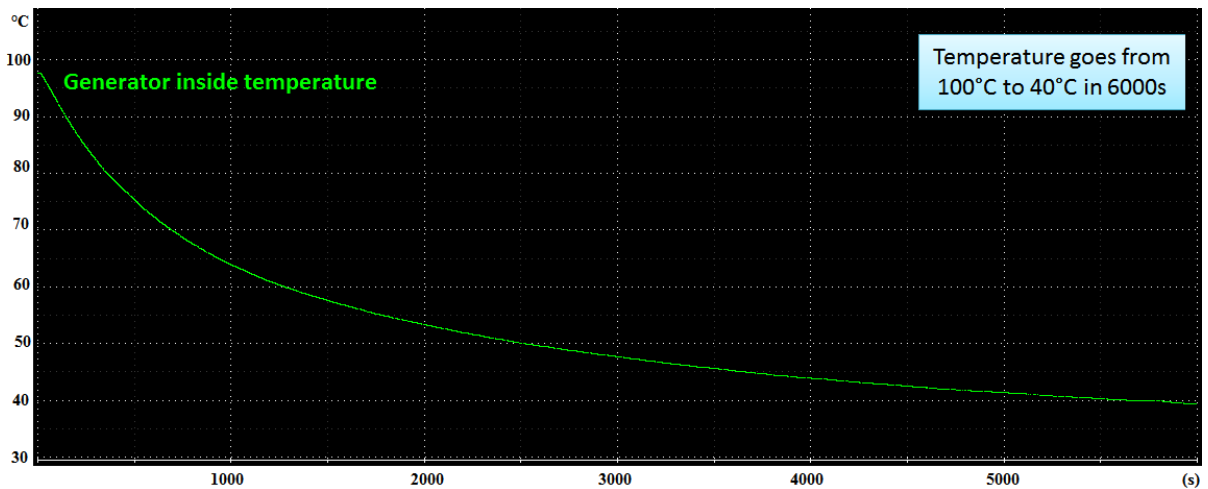

Figure 4.16: Time to cool the generator inside temperature

Another issue which was discussed, was to record the signal present on the CAN bus about the time of the day, and knowing how long the car has been turned off, may be possible to estimate this current temperature of the generator when the car is turned off. The problem is that it needs a lot of tests in many conditions, because this speed of cooling the generator temperature is not the same if the outside temperature is 30°C for example of if is -2°C.

4.3: Results

4.3.1: Modeling the dynamics of the systems

As described in the measurement plan, the strategy to model the system was to apply a known step value on the input (major influences), observe how the output (generator inside temperature) behaves and try to approach the measured curve into a first order system. Accordingly to the following rules:

In frequency domain, the first order transfer function is given by this relation between the output and the input $U(s)$:

$$\frac{Y(s)}{U(s)} = \frac{K}{\tau s + 1}$$

where:

$K = \text{Static gain}$

$\tau = \text{Time constant}$

Considering the response of this system for a step of magnitude, M :

$$U(t) = M \text{ for } t \geq 0 \rightarrow U(s) = \frac{M}{s}$$

So our output $Y(s)$ is given by:

$$Y(s) = \frac{KM}{s(\tau s + 1)}$$

Applying the inverse Laplace in the function above, we have our time domain output:

$$y(t) = KM(1 - e^{-t/\tau})$$

And be $y_{\infty} = \text{steady state value of } y(t) = KM$, we have:

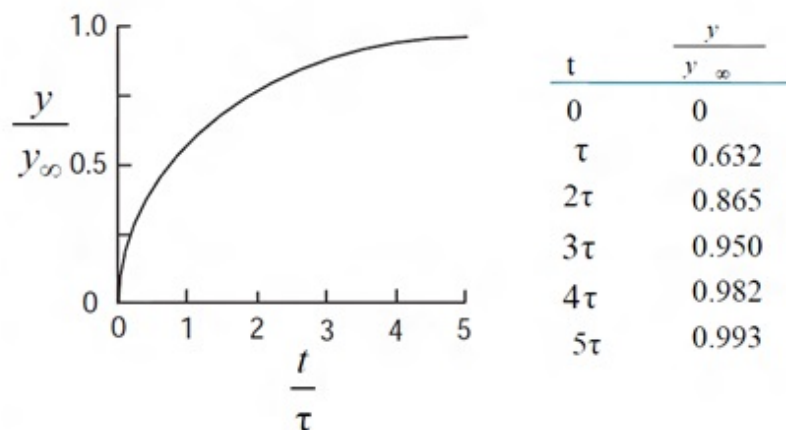

So for each major influence, the strategy of modeling was to observe the measured curve and get in which time the output value was around 0.632 (63.2%) of the steady state value. This way we got the time constant value (τ) and, with the value of K (static gain), we have our first order model that is a good approach to follow the measured curve.

This way, the idea was to apply defined steps (input $U(s)$) in the system of each major influence and to observe how the inside generator temperature (output $Y(s)$) behaves and from that, calculate the first order model of each one. With this, we would have different models which show how the generator temperature behaves in each interval of operation point and would have the contribution of each major influence on the final estimation of the inside generator temperature.

With our first order model in the frequency domain in the continuous time, it was used the command '**c2d**' in MATLAB which transforms our continuous time transfer function in a corresponding discrete time transfer function considering the sampling time, because the trigger in the MATLAB software in our case is of 0.1 seconds. For this reason it was necessary to use a command in this way:

DISCRETE TRANSFER FUNCTION = **c2d**(CONTINUOUS TRANSFER FUNCTION, 0.1)

After the tests, it was possible to put these discrete transfer functions on the MATLAB model and apply as an input of this system, the corresponding major influence signal from which it was modeled. This will be described in more detail in the next section.

With the modeled transfer functions we could observe how each major influence affects the inside generator temperature and, in theory, adding all the influences, we would gain our final generator temperature estimation.

But the problem was that, after the measurements, it was observed that the model followed really good the real measurements only sometimes or in some intervals. So it was discovered that this approach of modeling the transfer functions by linear system techniques was not so effective, because the non-linearity of the system in this case was very strong, causing different measurements for different initial conditions of the variables involved. Even this problem

was supposed since the beginning, it was thought that in this planned strategy, dividing the range of operation in many intervals and doing a different modeling for each one of them, this problem would be minimized enough to overcome this non-linearity, but after the measurements we saw that it was not a good approach in this case.

After many discussions with the professors of my university about this problem and a lot of research by myself, the best solution chosen for this case is to use the Hammerstein-Wiener model to correct and minimize this non-linearity problem of the system. This model consists of a non-linear block transfer function connected before the linear block to compensate this non-linearity of the system and shows very good results for this kind of problem.

Because when the output of a system depends nonlinearly on its inputs, it is sometimes possible to decompose the input-output relationship into two or more interconnected elements. In this case, you can represent the dynamics by a linear transfer function and capture the nonlinearities using nonlinear functions of inputs and outputs of the linear system. The Hammerstein-Wiener model achieves this configuration as a series connection of static nonlinear blocks with a dynamic linear block.

The block diagram shown in Figure 4.17 represents the structure of a Hammerstein-Wiener model:

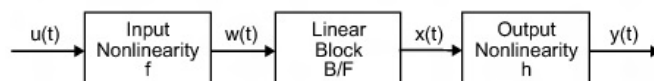

Figure 4.17: Hammerstein-Wiener structure

And to implement that, luckily there is a command on MATLAB called `'nlhw'` that does all this job, taking the time domain data that are our major influences signals, the linear model dynamics and with possibility of many fine tunings to improve the estimation of the output if it is still not good enough, such as initial condition, changing the non-linearity type of estimation and many other things. So this kind of approach is strongly suggested to be applied by the person who continues with this project.

4.3.2: MATLAB/Simulink model implementation

In this section all the MATLAB/Simulink model will be described, implemented after the tests and the continuous analysis of the data. This model will be detailed in 4 parts: the main model where the sum of influences are made to do the estimation, the influence of the coolant temperature, the influence of the current and the influence of the generator speed. As far as this model was developed, only the coolant and the current influences were really added to the model estimation, because the others did not have enough data for conclusion to be modeled.

4.3.2.1: Temperature Estimation Main Model

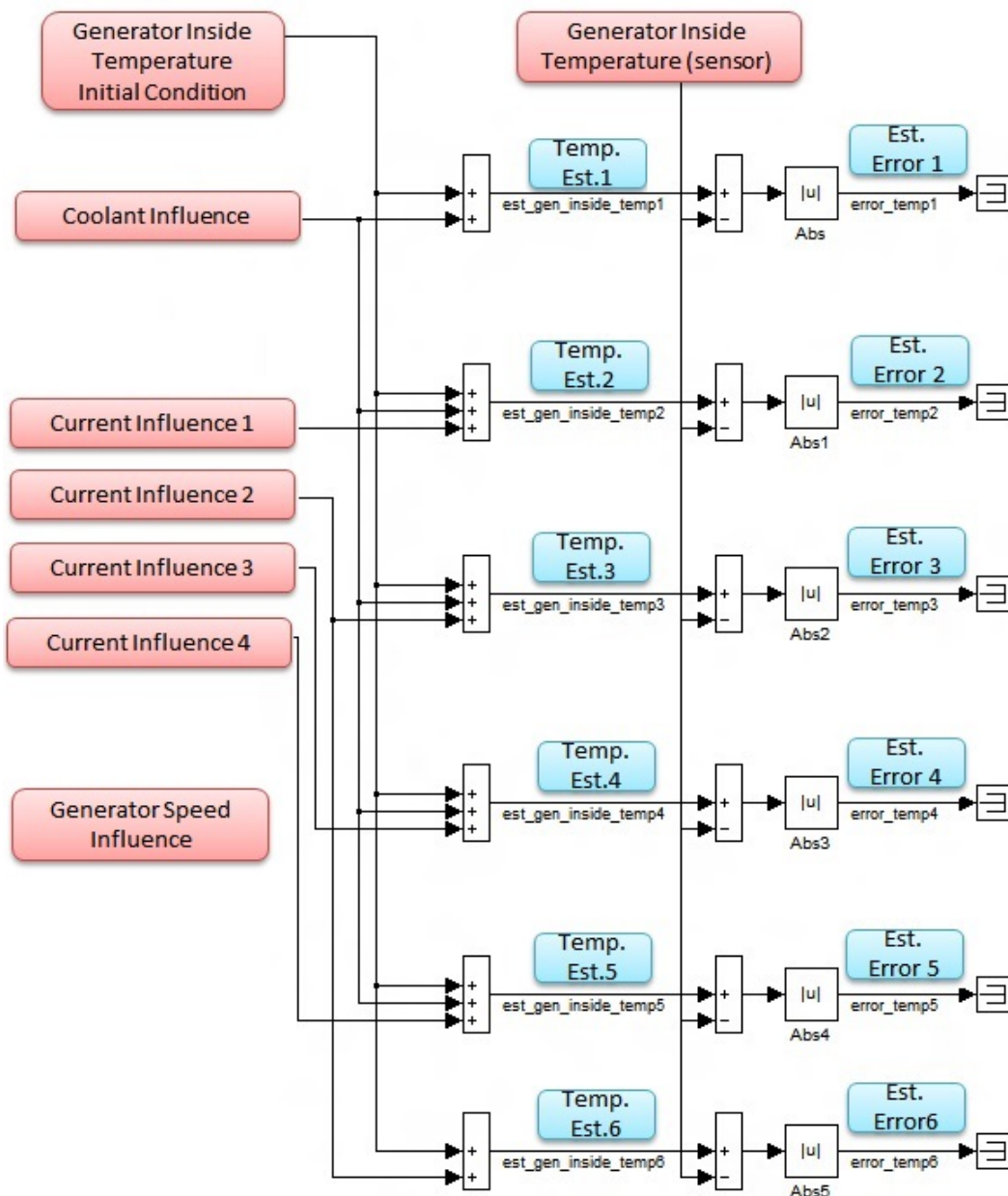

Figure 4.18: Temperature Estimation Main Model

In this part of the implementation shown on Figure 4.18, all inputs available are located for estimates the generator inside temperature in red color: the coolant influence and the current influence developed after the analysis data taken from the tests, the generator speed influence that still needs more tests to be added to the model, the real temperature of the inside of the generator taken from the sensor installed to compare and validate the model and also the initial condition of the inside temperature of the generator given by the user on dSPACE to be used on the estimation of the current temperature and consequently the error of it.

There are 6 attempts of estimation of the temperature in the blue boxes, each one added during the test that had been done to try to get as close as possible to the real temperature. Below it will be described how each one is composed:

- Temperature estimation 1: Initial condition + coolant influence.
- Temperature estimation 2: Initial condition + coolant influence + current influence 1.
- Temperature estimation 3: Initial condition + coolant influence + current influence 2.
- Temperature estimation 4: Initial condition + coolant influence + current influence 3.
- Temperature estimation 5: Initial condition + coolant influence + current influence 4.
- Temperature estimation 6: Initial condition + current influence 1.

With this attempts, it was possible to observe which of them went more close to the real temperature measured from the sensor and adjust the parameters and gains after every measurement. Some validations of this temperature estimations will be better detailed in the next section.

Also in the blue boxes, in the right of the figure, are the signals that corresponds to the error between the estimated temperature of the inside of the generator and the real temperature measured by the sensors. This way it was possible to see when and which estimation made a good approach of the temperature and continuously adjust and tune the model to improve the estimations.

4.3.2.2: Coolant Temperature Influence

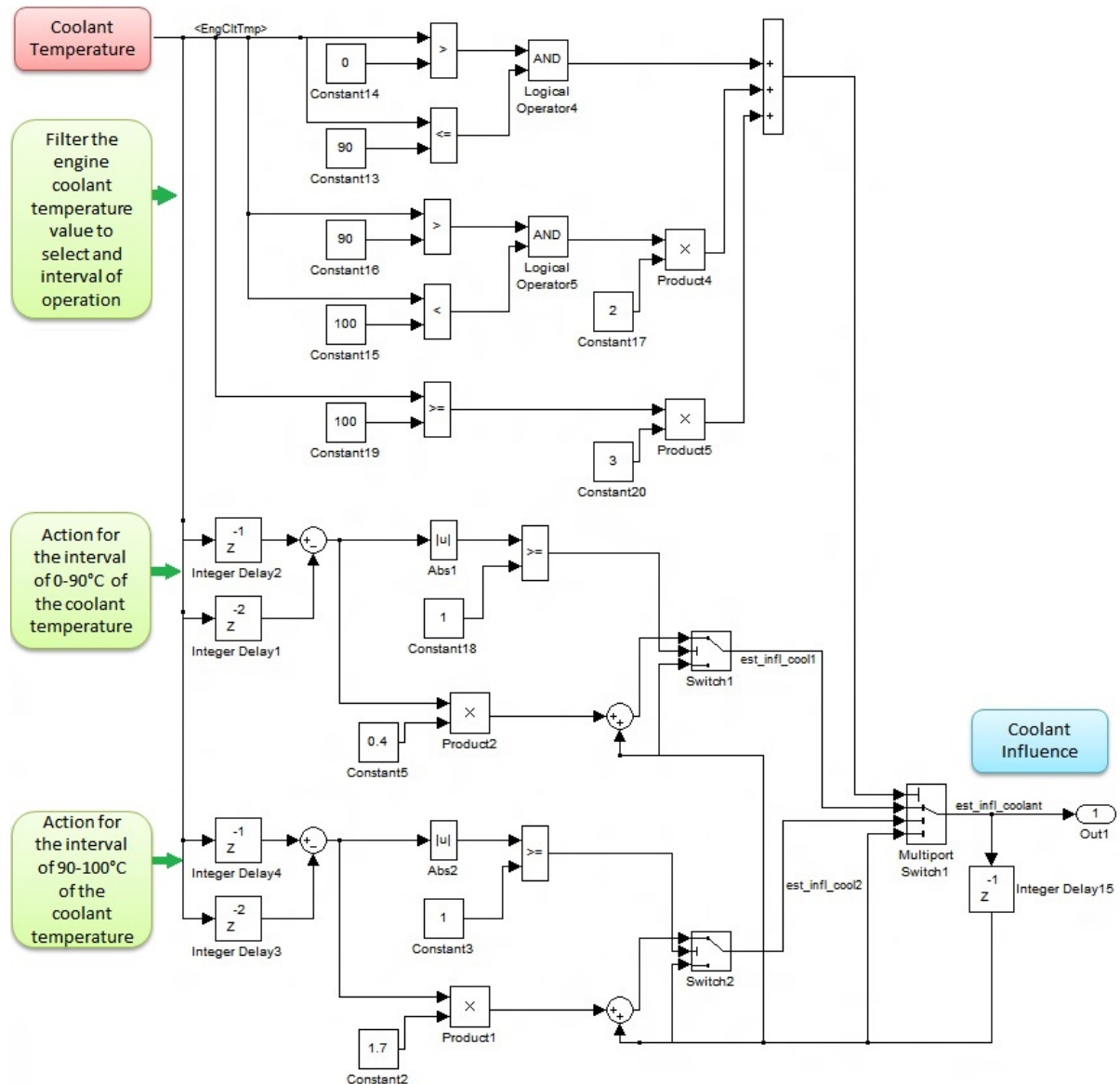

Figure 4.19: Coolant Temperature Influence Model

The model shown in Figure 4.19 was developed after the analysis of the coolant data taken on the tests and it had an almost linear behavior of the generator inside temperature when the coolant was rising its temperature, as seen on the figure /refcooltests below, where each line correspond to a different coolant test and they represent the generator inside temperature after many coolant tests. They are put together in this picture to better visualize the linear behavior of the generator inside temperature with the variation of this major influence:

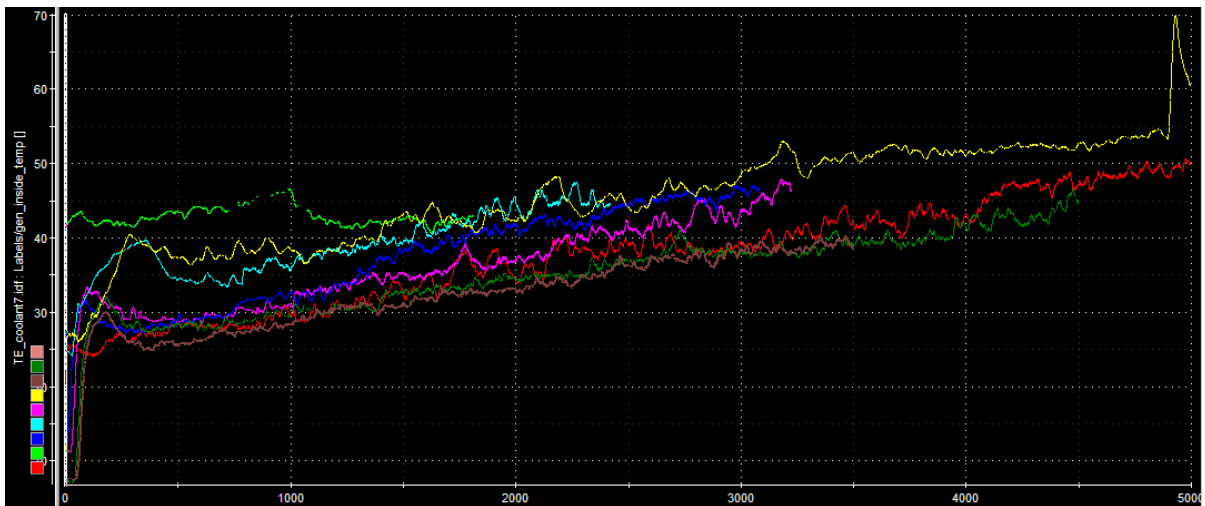

Figure 4.20: All the tests of coolant temperature influence together

And from this figure 4.20 it is possible to visualize this behavior mentioned, even if the operation points are different in each test, the inclination of this variation was very close. So all the inclinations of this curves were summed up and the average of this inclination was taken to be used in the model to simulate the influence of the coolant.

The average inclination taken from this test was 0.4°C added on the generator inside temperature after 1°C of variation of the coolant when it was from 0°C to 90°C , because after that, the valve that hold the coolant inside the engine opens and releases the coolant in the radiator circuit.

This way, after 90°C of the coolant temperature, another approach should be done, because the coolant took a long time to vary its temperature and the generator inside temperature keeps rising. So with the analysis done, the variation on this interval of operation of the generator inside temperature was around 1.7°C after 1°C of variation of the coolant temperature. For this reason, as shown in the Figure, the model was divided in more than one interval of operation to do a better approach of the behavior in each of them.

The modeling influence after 100°C of the coolant temperature was planned to be done, but after the tests, a huge disturbance was discovered caused by the engine fan, that starts when the coolant reaches this temperature, making a lot of noise on the measurement.

The disturbance is electric because when the fan starts the current goes up and then heats the generator and also thermic, because when the airflow starts, the heat taken from the engine stays in the place around the generator and consequently heat it up. So for this reason, in this model just the influence of the coolant until 100°C is considered. Figure 4.21 shows what kind of problem the coolant on this temperature brings:

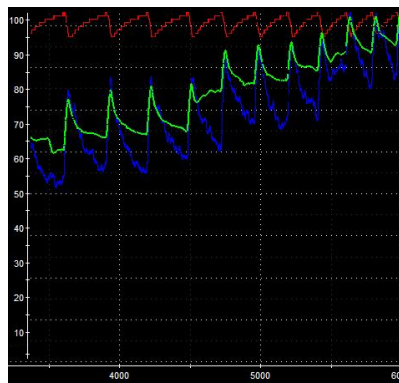

Figure 4.21: Disturbance caused by the engine fan after the coolant reaches 100°C

As we can see in Figure 4.21, when the coolant temperature (red color line) reaches 100°C, the fan starts and produces peaks observed on the generator inside temperature (green color) and on the generator outside temperature (blue color).

4.3.2.3: Generator Current Influence

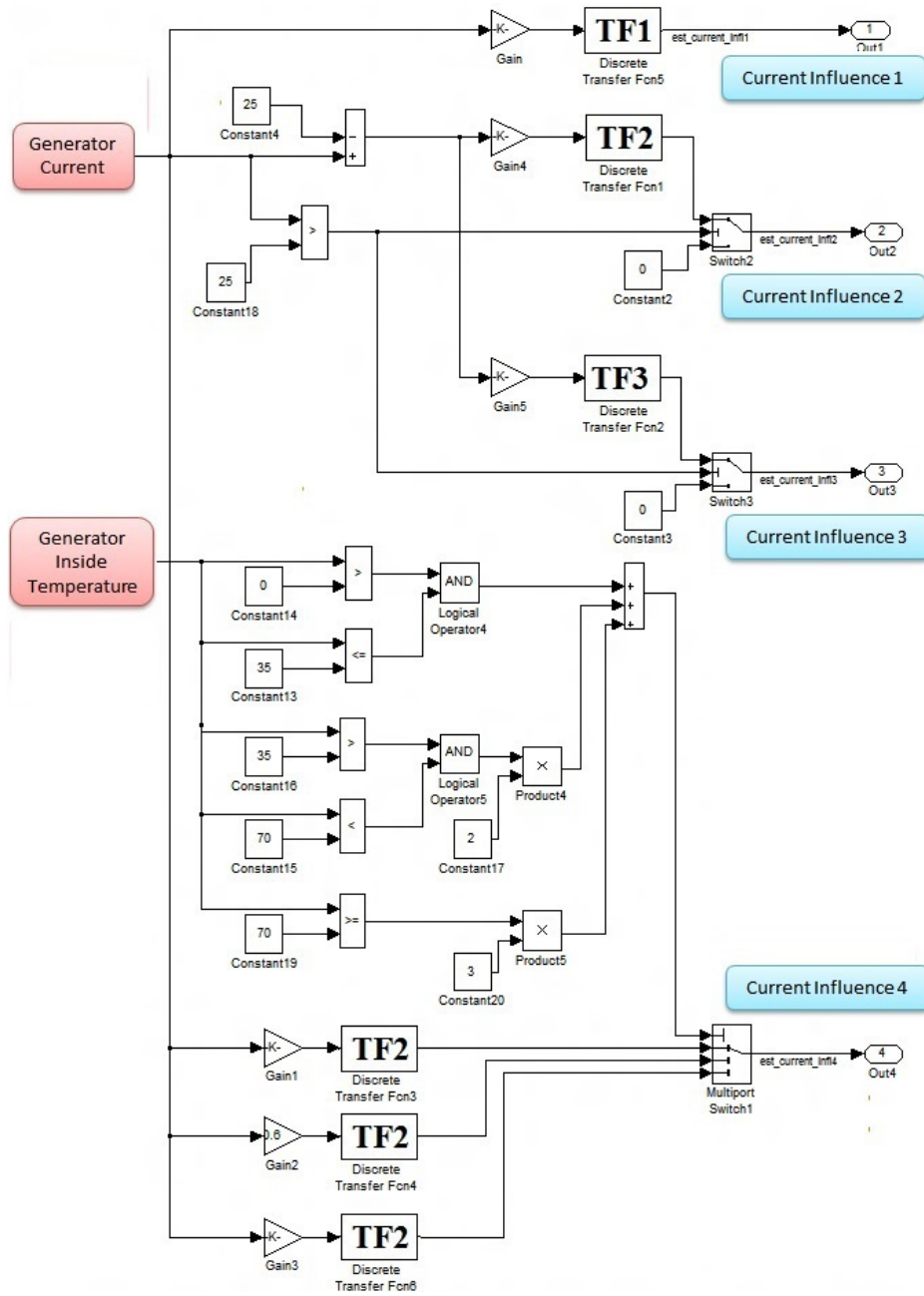

Figure 4.22: Generator Current Influence Model

Where in the discrete time domain 'z':

$$TF1 = \frac{0.0009995}{z - 0.999}$$

$$TF2 = \frac{0.0004999}{z - 0.995}$$

$$TF3 = \frac{0.0003}{z - 0.997}$$

The step response of this 3 different transfer functions are shown in the Figure 4.23. We can see that the TF1 has the slowest dynamics to reach the steady state value and TF3 has the fastest of them:

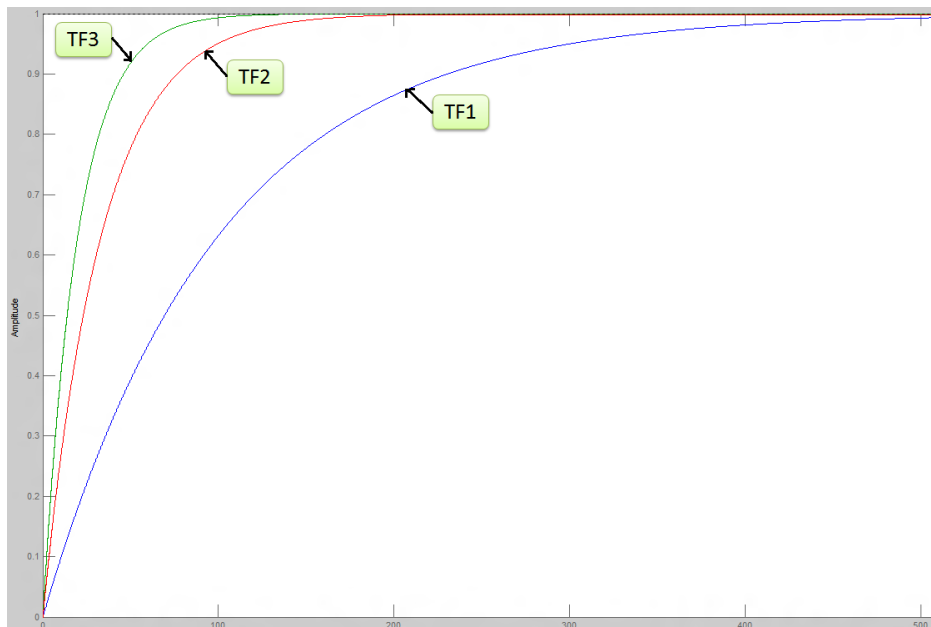

Figure 4.23: Step response of the transfer functions of the current influence

The influence of the current on the generator inside temperature is implemented as shown in Figure 4.22. It has 4 kinds of approaches tested, which are represented in the blue boxes:

- Current Influence 1: defined by the static gain $K = 0.65$ multiplying the transfer function TF1.
- Current Influence 2: defined by the static gain $K = 0.65$ multiplying the transfer function TF2 but this influence is just triggered when the generator current is higher than the standard current of the car: 25A.

- Current Influence 3: the same as the Current Influence 2, but it has a different approach for the dynamic of the system, described by the transfer function TF3.
- Current Influence 4: this influence takes as reference the current inside temperature of the generator and, for each different interval of operation, switch the flow of the influence to a different static gain for the system, but all of them with the same dynamics represented by the transfer function TF2. The gain for the interval of generator inside temperature between 0°C and 35°C is $K = 0.75$, the gain for temperatures between 35°C and 70°C is $K = 0.60$, and the gain for temperatures above 70°C is $K = 0.45$.

With the tests on the generator current, it was clearly observed that an offset on the generator inside temperature was done in consequence of this variation on the current and the dynamic of this variation during all the steps was not the same but they were not so much different from each other. This way, the biggest difficulty to get the best estimation of this influence was to determine the right static gain to put on the system depending on the value of input of the generator current.

As mentioned before, with the tests made, it was observed that the system is strongly not linear, which means that for the same input of current, the system can react in a different manner depending on the initial conditions. For example in Figure 4.24 we can see this problem:

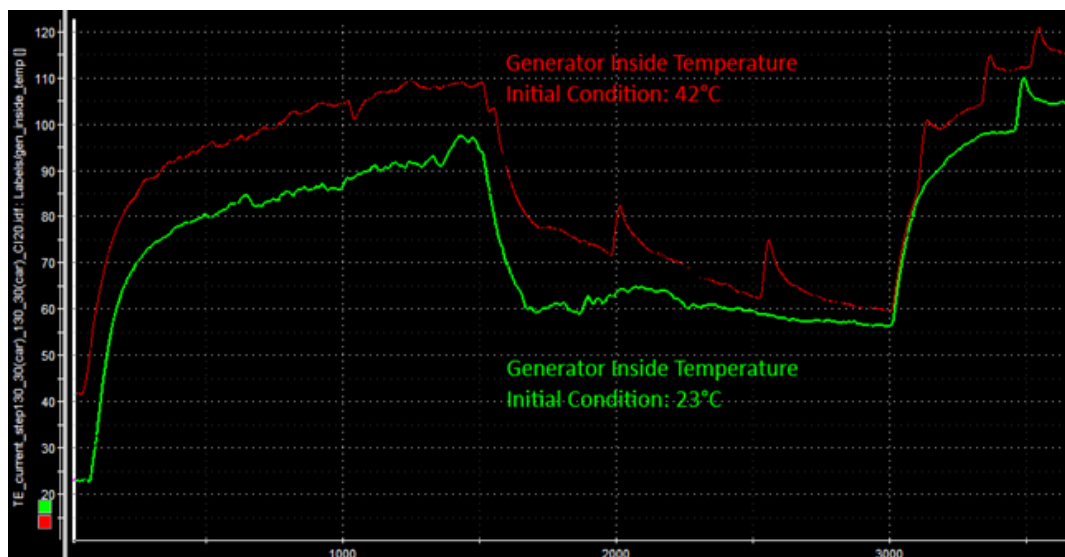

Figure 4.24: Different outputs of temperature for the same input of current

For the same input of 100A of current on the generator, we had 2 different curves and steady state values. Because in one test our initial condition of the generator temperature was 23°C and the other one was 42°C and even if the dynamic of this temperature variation are similar in both cases, our intermediate and final values are not linear just depending on the input of current we put on the generator.

And for this reason many attempts and changes on the model was done to overcome this non-linearity somehow: changing the dynamics of transfer function, changing the gain, switching the model, but none of them were effective all the time, just in some intervals they had a good approach but after some time the error starts to get big.

So for this reason, this model needs to have more tests to get more behavior of this influence in all the conditions and improve the approaches on the model or change the strategy, which is a much better solution, and use non linear techniques like that mentioned before called Hammerstein-Wiener model, which have a non linear block before the linear dynamics to overcome this problem that is happening in this model.

4.3.2.4: Generator Speed Influence

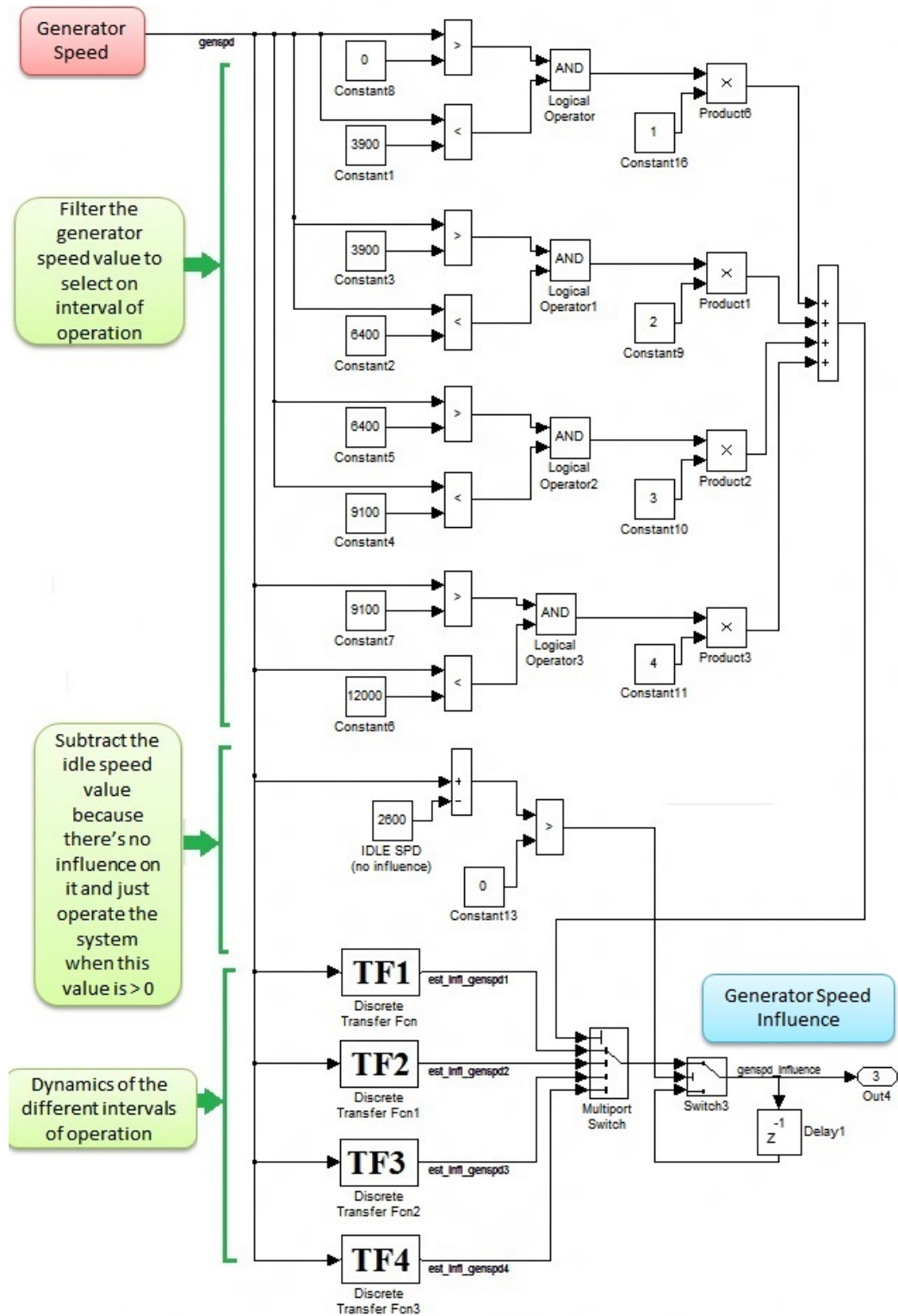

Figure 4.25: Generator Speed Influence Model

Where in the discrete time domain 'z':

$$TF1 = \frac{2.545e^{-11}z + 2.545e^{-11}}{z^2 - 2z + 0.9999}$$

$$TF2 = \frac{1.094e^{-10}z + 1.094e^{-10}}{z^2 - 2z + 0.9999}$$

TF3 and TF4 = not developed

This model of the generator speed influence was not added to the main estimation of the temperature because, as mentioned before, the tests and the modeling do not give an accurate measurement of this influence. But based on the measurements done for this influence, this model was built with the same idea as the one with other influences, doing the modeling for 4 different intervals of speed and putting the dynamic observed in each transfer function that represents this range of speed. Some tests were made for speeds of the generator in 2500 rpm and in 5000 rpm, then this 2 models were taken and represented by TF1 and TF2 respectively. The tests for higher speeds were not good enough, so models were not made for them.

Besides the tests for this influence were not accurate for all the ranges, it was tried to use this models on the final estimation but it was not a good approach. And until now, it is not known if the modeling is not enough accurate or how this influence must be added to the model: just with regular sum on the influences or if this signal contributes in other major influences, such as the coolant temperature, as supposed after the tests.

4.3.3: Validation

The box represented on Figure 4.26 refers to the curves on the graphics shown on Figures 4.27, 4.28 and 4.29:

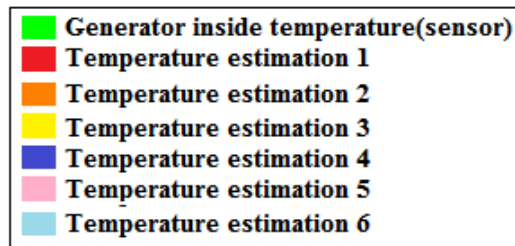

Figure 4.26: Labels indicating the colors on the validation graphics

Figure 4.27 shows a validation done with the car stopped, engine idle, outside air temperature of 22°C and applying a step of 100A on the generator current in this conditions:

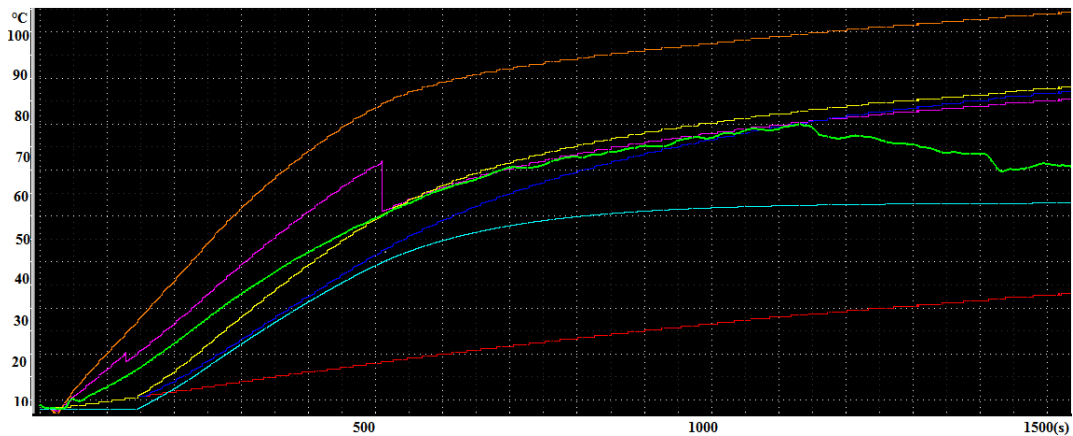

Figure 4.27: Validation 1 of the temperature estimation

Figure 4.27 shows a validation done with the car stopped, engine idle, outside air temperature of 22°C and varying the generator current randomly in this conditions:

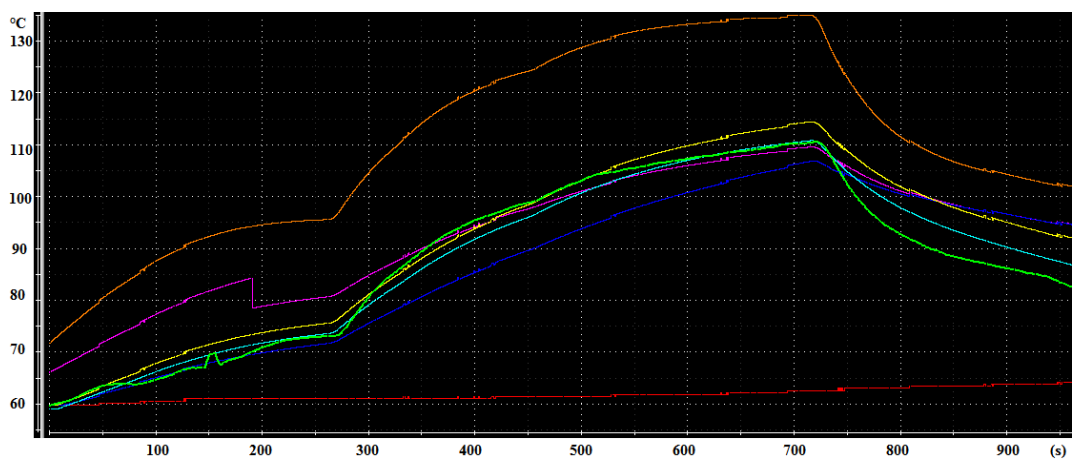

Figure 4.28: Validation 2 of the temperature estimation

As we can see in Figures 4.27 and 4.28, the temperature measured by the sensor is well approached for one type of estimation in one interval, but the same estimation may not be so good in other intervals of measurement as well. It means that these estimations can do a good approach of the real temperature measured by the sensor, but not in all the range of measurement because the system behavior depends all the conditions involved, because this is a non linear system and our attempt was in a linear system technique. So this behavior is expected after the attempt of estimation it was proposed in this case.

Figure 4.29 shows a validation done in a real case driving the car, doing different things like changing speed, turning on the AC and headlights, stopping the car and everything else. The results show that the estimations follow the dynamic of the real measurement, but the static gain of these estimations are not accurate perfectly estimate the temperature inside the generator. This thing might be solved with the implementation of the Hammerstein-Wiener model which can overcome these non linearities and put the right static gain for the system to do a good estimation.

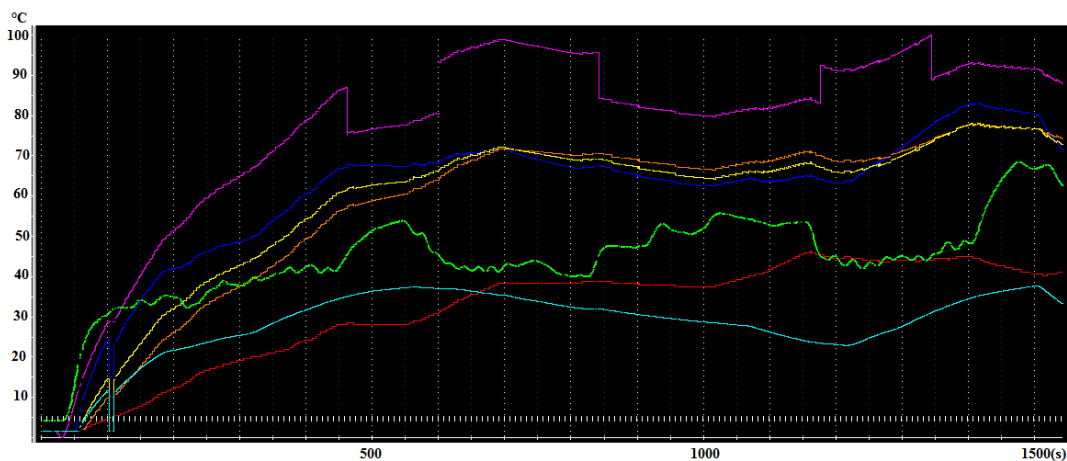

Figure 4.29: Validation of the temperature estimation in a real case test

Another thing observed in this real case test is that even with big changes on the car like turning on the AC or headlight, which in the tests made with the stopped car did a big change on the generator inside temperature, in this case the temperature stayed around 40°C even after all these kind of modifications on the influences and driving changes too. This behavior is supposed to be this way because the airflow does the opposite influence on the temperature, compensating the influence of the other signals varied on the test. So after the airflow tests are done, this supposition can be checked, because in this model the airflow could not be modeled, that is another reason for these estimations are not as accurate as expected.

4.4: Perspectives

- Discover a way to have an accurate initial condition estimate for the temperature estimation.
- Continue the tests for all major influences using the climate room and the bench test as initially planned.
- Do these tests not only with a car stopped but also define a cycle on the city to perform these tests and also do this test on the road to cover as much conditions possible.
- Analyze the data and take the models for this influences from the tests.
- Apply the Hammerstein-Wiener model to try to minimize the non-linearities of this system.
- Validate the implemented model with this technique to check if the approach is accurate enough.
- Start the second part of the project to estimate the generator current, which is dependent of generator temperature.
- Build a table or algorithm to estimate the generator efficiency based on the generator temperature and current estimation.

Capítulo 5: Conclusion

This project was developed to create an estimation of the inside temperature of the generator to be used on an efficiency way of charging the battery, in order to reduce the emission of CO₂ in the cars.

The inicial plan of the project was to do the step response test for all the major influences and with this linear system approach, obtain the transfer function for all of them to sum the contribution of each one on the final estimation of the temperature of the generator. But the problem was that the problem is more complex than imagined so this solution did not provide an accurate solution for this modeling.

The interdependency of the influences was also a big difficulty because it was hard to separate the influence of them in the output, making the analysis not so accurate sometimes. Another big problem was the time available to develop all the planned tests of the project, that it was not enough to cover everything desired.

For the six major influences planned to be modeled in this project, three were tested and modeled: engine coolant temperature, generator current and generator speed, but only the first and the second mentioned had an acceptable result to be added in the main model of the estimation. The last one(generator speed), besides the many tests developed could not have a good conclusion.

This way our final estimation of the generator temperature could not reach the desired accuracy because it still needs more tests and improvements to have a good result. As mentioned, some different kind of tests could be implemented to minimize the interdependency of the influences such as bench tests and tests in a climate room for example, to give better results without the disturbances faced in the tests of this project.

Independently of this project did not reach the desired final result, it could show how some influences contributes for the generator temperature and with the continuation of the tests, the modeling and the application of different techniques like the non linear approach, it can give

good results, because even without modeling all the influences, the model developed could give good results in some intervals of measurement, so the expectation for the future of the project is very high.

Besides this mentioned steps for the future, the measurement plan needs to be changed to add tests with the car not stopped, like in a defined circuit on the city and also in high speeds in the road to cover more different conditions as possible for the estimation. With this changes and the continuation of the tests, the inside temperature estimation of the generator has big chances to be successful and accurate to be the desired step to develop the efficiency dependent way of charging the battery for the company.

References

- [1] B.P. Lathi, "Signal processing and linear systems", Oxford University Press Inc; 2nd international edition, 2009.
- [2] Ogata, Katsuhiko, "Engenharia de Controle Moderno", Editora: LTC, 3 Edição, 2000.
- [3] Pyrhönen, Juha, "Design of Rotating Electrical Machines", 1st edition, 2009.
- [4] Nasar, Syed, "Linear Electric Actuators and Generators", Cambridge University Press, 2005.