

**DAS** Departamento de Automação e Sistemas  
**CTC** **Centro Tecnológico**  
**UFSC** Universidade Federal de Santa Catarina

# **Developing controls for a 12V lithium-ion starter battery.**

*Report Submitted to Federal University of Santa Catarina, as*

*requirement to approval in subject:*

***DAS 5511: End of Course Project***

***Lucas Ventura***

Rüsselsheim, July 2014

**Developing controls for a 12V lithium-ion starter  
battery.**

***Lucas Ventura***

***Supervisors:***

**Dirk Balzer, Dr-Ing.**

---

***Supervisor Signature***

***Prof. Dr.-Ing. Julio Elias Normey-Rico***

---

***Supervisor Signature***

This report was jugged in the context of the discipline  
**DAS 5511: End of Course Project**  
And approved in its final version by  
**Course of Control and Automation Engineering**

*This report contains proprietary information of Adam Opel AG that is not intended for public use.*

*All rights of this work including electronic treatment are within Adam Opel AG.*

*During a time period of 3 years the content of this report has to be treated confidential and any exemption to above statement needs an approval of Adam Opel AG.*

*Rüsselsheim, Germany, July 2014*

## Acknowledgements

First of all I want to give my major thanks to my parents, Lidnei and Ronilda Ventura, my aunt, Rosa Machado, and all my family for the incredible support given to me until this point, this achievement is both theirs and mine.

Also, greetings to Dr. Dirk Balzer for giving me the opportunity of an international experience in Germany, as well to my work colleagues and Koos Leertouwer for all the help and experience shared.

My thanks as well to the people that followed the path with me and stood together during the sleepless nights: Natan Grando, Leonardo Gobbi and Gustavo Martins. For the consultant job I would like to credit Fernando Elias de Oliveira and Luiz Renato Tomelin, for the saved time.

For the extra help, directly related to my study or not, my gratitude to all my close friends that were with me in those years: Alecsander Mattos, Andjara Consentino, Débora Gardinal and José Augusto Panzarin.

At last I would like to thank my girlfriend Diana Tuaty for helping me during the last steps of this journey and all the people that aren't cited here but contributed somehow for this objective.

## **Abstract**

When we enter in the concepts of the automotive industry, developing technology is a crucial factor. Each period elapsed demands modern features and new norms are set, which implies in a constant research for new options to improvements and means of decrement costs.

In order to be prepared to future standards, the company Adam Opel AG (subsidiary of GM, Rüsselsheim - Germany) is studying how different kinds of batteries react in alternative to a Lead-Acid Starter Battery, used in most of the ordinary vehicles.

The idea of this project is to implement a Lithium Iron Phosphate Battery as replacement option to a regular one, going through the process of searching its potential and properly developing the necessary controls. It's known that a Li-Ion has improved characteristics and can be more explored to upgrade the electrical parts, a motivation to use it.

Following this approach, is presented a brief overview of the electrical system, serving as background to understand the battery and how we manipulate it to getting better results.

As a final step, with the battery fully functional in the vehicle, validation tests will be performed, which is crucial to obtain results that measure the performance of our approach. Comparing both batteries is a very important task, mainly due the fact that a Lithium Iron Phosphate Battery has a higher price in the market and its performance must justify and cover the replacement with extra features and better behavior.

## Resumo

Quando entramos no conceito de indústria automobilística, o desenvolvimento de novas tecnologias é um fator crucial. Cada ano que se cumpre exige atualizações de diversas funções, além de novas metas a serem cumpridas, o que implica na necessidade de pesquisas constantes visando novas opções para melhoramentos e meios de decréscimo de custos.

Com o intuito de preparar-se para futuras normas, a companhia Adam Opel AG (subsidiária da GM, Rüsselsheim - Germany) está estudando como diferentes tipos de baterias se comportam em alternativa a uma bateria principal de Chumbo-Ácido, utilizada na maior parte dos veículos comuns.

A ideia central deste projeto é implementar uma bateria de Fosfato de Lítio-Ferro como uma substituta de uma bateria comum, entrando no processo de pesquisa de potencial e o devido desenvolvimento de controles para o novo equipamento. Sabe-se que uma bateria de Li-Ion possui características superiores e pode ser explorada para aprimorar o sistema elétrico, o que é uma das razões pela escolha do componente.

Seguindo esta linha de raciocínio, é apresentada uma breve explicação do sistema elétrico, servindo como base para um melhor entendimento da bateria e como é possível manipulá-la para obter melhores resultados.

Para a etapa final, com o novo sistema em pleno funcionamento, serão realizados testes de validação, cujos são cruciais para a obtenção de resultados que avaliam o desempenho de nossa solução. A comparação de ambas as baterias é uma tarefa de extrema importância, principalmente devido ao fato de que uma bateria de Fosfato de Lítio-Ferro tem um preço mais alto no mercado e seu rendimento deve justificar e cobrir os custos da substituição, seja com funcionalidades novas ou com melhor comportamento.

# Contents

Acknowledgements.....	iii
Abstract .....	iv
Resumo .....	v
Contents .....	vi
Symbology.....	ix
List of Figures .....	x
List of Tables .....	xi
Chapter 1: Introduction .....	1
1.1 Adam Opel A.G. ....	2
Chapter 2: Electric Power Management (EPM) Overview .....	4
2.1 Related Components.....	4
2.1.1 Generator .....	4
2.1.2 Starter Battery .....	5
2.1.3 Intelligent Battery Sensor (IBS) .....	8
2.1.4 Internal Loads .....	8
2.2 Embedded Controls.....	9
2.2.1 Body Control Module (BCM) .....	10
2.2.2 Engine Control Module (ECM) .....	11
2.2.3 dSPACE MicroAutoBox.....	12
2.3 Hardware Configuration and Information Flowing .....	12
Chapter 3: The Lead-Acid Battery and Vehicle Behavior.....	14
3.1 Historical Background.....	15

3.2	Characteristics and Influence in the Automotive Sector .....	15
3.2.1	Weight .....	16
3.2.2	Charge Acceptance .....	16
3.2.3	Environment Impact .....	17
3.2.4	Behavior with Low Charge .....	18
3.3	Possible Improvements .....	18
Chapter 4: Using a Lithium-Iron Phosphate Starter Battery .....		21
4.1	Characteristics and Potential .....	22
4.2	Objective and New Features .....	24
4.3	Necessary Changes .....	25
4.3.1	Hardware .....	25
4.3.2	Software .....	26
Chapter 5: Building the Controls .....		27
5.1	Simplified Simulink Structure .....	27
5.2	Logical Controls and Operating Modes (BCM) .....	28
5.2.1	Normal Mode .....	30
5.2.2	Head Lamps Mode .....	30
5.2.3	Fuel Economy Mode .....	31
5.2.4	Recuperation Mode .....	32
5.3	Closed Loop Controls (ECM) .....	34
5.3.1	Voltage Control .....	35
5.3.2	Current Control .....	37
5.4	dSPACE Interface .....	39
Chapter 6: Measurements, Validation Tests and Results .....		40
6.1	Real Driving Measurements .....	40
6.2	WLTP Validation Test .....	42



6.3 Starting Performance.....	43
6.4 Measurements to be done.....	45
Chapter 7: Conclusion .....	46
Chapter 8: References.....	48
Appendix A – Lead-Acid Batteries: Flooded vs AGM .....	49
Appendix B – Test Cycles.....	50

# Symbology

## Acronyms

BCM – Body Control Module

CAN – Controller area network

ECM – Engine Control Module

EPM – Electric Power Management

FEM – Fuel Economy Mode

HLM – Headlamps Mode

IBS – Intelligent Battery Sensor

LI-ION Battery– Lithium Iron Phosphate Battery (LiFePO<sub>4</sub>)

LIN Bus – Local Interconnect Network

HS-CAN – High speed CAN

REC – Recuperation

SOC – State of Charge

OCV – Open Circuit Voltage

WLTP – Worldwide Harmonized Light Vehicle Test Procedures

## List of Figures

Figure 1: Generator being activated by the engine belt. ....	5
Figure 2: Automotive starter battery composition. ....	7
Figure 3: Intelligent Battery Sensor. ....	8
Figure 4: Control modules composing the EPM. ....	9
Figure 5: ECM Closed Loop. ....	12
Figure 6: Charging system circuit. ....	13
Figure 7: Electrical system's information flow chart. ....	13
Figure 8: Rechargeable batteries market distribution. ....	14
Figure 9: Charge capacity of a Lead-Acid AGM battery.....	17
Figure 10: Sulfation on battery's plates.....	18
Figure 11: Comparing SoC behavior in different types of batteries. ....	19
Figure 12: Lithium Iron Phosphate Battery discharging .....	21
Figure 13: Charge capacity of a LiFePO4 battery.....	23
Figure 14: New hardware adapted to the Li-Ion battery.....	25
Figure 15: Simulink structure of the control modules.....	28
Figure 16: Optimal charging voltage .....	29
Figure 17: Control switching structure .....	34
Figure 18: Voltage control structure.....	35
Figure 19: Step response of the system .....	35
Figure 20: Current control structure.....	38
Figure 21: Current response to voltage step.....	39
Figure 22: Dspace Interface .....	39
Figure 23: Reference changing during driving test .....	41
Figure 24: Recuperation event .....	42
Figure 25: Energy balance on WLTP.....	43
Figure 26: Lead-Acid voltage drop.....	44
Figure 27: Lithium-Iron Phosphate voltage drop.....	44

## List of Tables

Table 1: Lead-Acid AGM and Lithium-Ion (LiFePO <sub>4</sub> ) characteristics .....	23
Table 2: Lithium-Ion operational modes.....	26

# Chapter 1: Introduction

Automotive companies are in a constant race to get a better place in the market, since a long time there are a fair amount of resources being invested in order to upgrade their products. Being in a continuous improvement is important due to the fact that new technologies arise every time and they can be integrated in the vehicles, making them better and safer.

An important development line was carried around the battery field, used originally to create the electric start and replacing the dangerous manual cranking of the first vehicles [1]. Their notoriety has grown and nowadays they have the role of, besides the cranking, feed the electronic components, reducing the loads connected to the generator and therefore the fuel consumption.

The automotive batteries currently in use today were created by the end of the XIX century and popularized in the beginning of the XX, composed by a Lead-Acid chemistry (section 3.1 extends this subject), being upgraded since then. However those batteries, because of their inner characteristics and behavior, no longer correspond to the companies' future expectations, leading to a new era of researches focused on different configurations and chemistries, one in particular is the starter Lithium-Iron Phosphate Battery alternative, described in this document. Furthermore, there are plenty of possible solutions being studied that won't be described, as in the case of using an auxiliary secondary battery [2].

This project started by the company Adam Opel A.G. looks forward to make a setup based on a Li-Ion starter battery trying to explore new possibilities with adapted controllers (see section 5.2) and evaluate the results studying the future possibility of mass production.

To enable the proper research, a Lithium-Iron Phosphate battery will replace a regular Lead-Acid Battery in the electrical system. So, for a better understanding, the next chapter will briefly explain the EPM (Electric Power Management), showing its components and data exchanging.

Chapter 3, as already mentioned, will introduce the historical roots of the Lead-Acid battery and how it behaves inside the vehicle. Moreover, some key

characteristics that have a direct impact on the car performance or in the environment will also be presented.

The expected changes, together with the Li-Ion battery, will be shown in chapter 4, where the extra features about the hardware and the control software are highlighted.

The proper development of the controls are explained in chapter 5, including the logical strategy to explore the new battery more efficiently and the closed loop controls related to the generator's set points, in voltage or current values. Here it is important to mention that the whole control strategy is based on changing the generator's voltage as a decision to charge the battery or to use it to support the loads.

A very important point that should be emphasized during the development of this project is the final results obtained with the upgraded Li-Ion configuration in comparison with the Lead-Acid's. The decision to a future production is strongly affected, mainly because the actual cost of lithium-based batteries is much higher than the regular ones and it is necessary that its efficiency in operation should be able to compensate these values. The results obtained in the tests with the changed system will be presented in chapter 6 and will directly compare both batteries.

At the end several final conclusions will be presented, explaining the positive and negative points of our approach, yet, showing what still can be explored or couldn't be done during the internship period.

## **1.1 Adam Opel A.G.**

Opel nowadays is a German automotive company subsidiary of the General Motors. It was founded by Adam Opel in 1862 in Rüsselsheim, Hessen as a sewing machine factory, later on entering in bicycles market as well. However, the company only began to produce vehicles after Opel's death in the 1890s, when his son started a series of partnerships until its sale to GM in 1929.

The Adam Opel plant grew as one of the largest German manufactures of vehicles through the years until its total destruction in during the World War II, where Allies' aircrafts bombed the area.

In the following years, Opel was rebuilt and reassumed by GM, slowly returning to the automotive market, building trucks and passenger cars.

Today Opel has factories in Bochum, Kaiserslautern and Eisenach, besides the headquarters in Rüsselsheim. It counts with about 37 thousand employees installed in Europe.

The current passenger cars Opel in manufacturing are:

- Opel Adam;
- Corsa;
- Astra;
- Ampera;
- Insignia;
- Cascada;
- Agila;
- Combo;
- Meriva;
- Zafira Tourer;
- Vivaro;
- Movano;
- Antara;
- Mokka.

In Brazil, some Adam Opel products are sold under the brand Chevrolet, also a subsidiary of General Motors.

## Chapter 2: Electric Power Management (EPM) Overview

The Electric Power Management, frequently referred to as EPM, is a monitoring system present in the running vehicles, designed to handle a group of components included in the electrical system.

When activated the EPM tracks the elements' status and uses embedded control modules to activate the desired operational mode. Those modes, which will be detailed later in this chapter, define the charging (or discharging) strategy in order to improve the driving process and guarantee the good condition of the parts [3].

Next section presents the main components related to the EPM, giving a short introduction of their structure and how they can be explored in the vehicle.

### 2.1 Related Components

To allow the automatic start and feeding the *internal loads*, the electric system, or charging system, is equipped with two energy sources: a *battery* and a *generator*, with the first being responsible for the engine-start and both alternating to support the loads.

Often the battery needs to be charged by the generator and that decision is taken by the *embedded control modules* (see section 2.2) composing the EPM after reading the *Intelligent Battery Sensor (IBS)*, which provides data from the battery. Those components are interconnected by a high speed CAN bus or a serial LIN network.

#### 2.1.1 Generator

The generator is the main source of electricity once the car is running, it is directly related to the engine movement (see Figure 1), using its rotation to generate an alternate current (AC). The current later on is rectified and converted to a DC value going from a minimum of 11V and to a maximum of 16V.



Usually this electricity is used to support the electrical loads and recharge the battery when necessary. Although, sometimes the generator is deactivated and the battery takes the supplying role, reducing fuel consumption (this behavior constitutes the fuel economy mode, explained in the following sections).

The generator's operational point is calculated by the control models and is set in the form of a PWM signal. The PWM duty cycle defined is called *L-Term* and is the variable manipulated to actuate in the system. It works changing the current in the generator's rotor, varying its own field and, consequently, the voltage generated [4].

As a feedback of the generator's effort we have a second variable, named *F-Term*.



Figure 1: Generator being activated by the engine belt<sup>1</sup>.

### 2.1.2 Starter Battery

When the vehicle's engine is turned off, the generator can't be used to produce energy, which requires an extra electricity source to be used in this condition when necessary. Because of that, there is a powerful 12V (six 2V cells) battery installed, and its power varies depending on the car.

Commonly known as a starter battery (see Figure 2), this component got the name because its main task is the electrical cranking, as commented before, avoiding the manual start. Also, it is often used to feed the loads in determined situations.

---

<sup>1</sup> Source: <https://encrypted-tbn1.gstatic.com/images?q=tbn:ANd9GcTna2aJhcAY9cnJP4cU6IE5Ww7pFYIJ3ByAQ3bj8S7PkSw018Zh0w>

There are different types of starter batteries and their behavior is strongly affected by their chemistry composition, being the Lead-Acid option the most common (see chapter 3), which is included in the majority of vehicles. Moreover, other configurations are getting popularized, as in the case of lithium-based ones.

When we talk about batteries, it's important to explain some fundamental concepts that will be later necessary for the EPM controllers and performance measurements:

- *Capacity*: Normally measured in ampere-hour (Ah), the battery capacity is the default way to evaluate automotive batteries. The capacity represents how much of charge is stored inside the battery and what is the maximum amount of energy that can be extracted. The unit Ah, in theory, represents how many hours we can discharge the battery using a current of 1A, although in practice this concept is tricky and the capacity value should be decreased (using a current of 4A instead). A starter battery could have from 40 Ah up to 95 Ah of capacity.
- *State Of Charge (SOC)*: Represents, in percent form, how much of the battery's capacity is remaining. The SOC is estimated by the ECM and is a key variable for the controllers, used to take decisions about the vehicle's operational mode. Tracking the state of charge is crucial for security reasons as well, since the battery changes its own characteristics depending on the actual capacity.
- *Voltage (V)*: The voltage related to the battery could mean two distinct things, depending on the situation. The first case is the nominal voltage, provided by the supplier, which represents the average of energy that can be given when supporting the loads and depends only on the battery. On the other hand, there is the voltage measured in the battery's electrolytes, this value shows the voltage when the battery is under the effect of another electric tension source, in this case, powered by the generator. Usually, it's possible to measure values a few volts higher than the nominal value, depending on the generator's voltage.

- *Open Circuit Voltage (OCV)*: This parameter is used often to recalibrate the State of Charge status and it can be obtained measuring the voltage of the battery after a long resting time (over 8h), that is, when the component is no longer under effect of external tension sources for a long period.
- *Current (A)*: The current passing through is used to check whether the battery is being charged by the generator or discharging and how the electrical charges are moving. Furthermore, the current flowing is very important when controlling the battery's SOC.
- *Internal Impedance (Ohm-Ω)*: Following the Ohm's law, the internal impedance of the battery is inversely proportional to the current going through it, since the charging voltage is constant during the steady state of the operational modes defined by the EPM. The lower the internal impedance, the faster the battery can be charged.

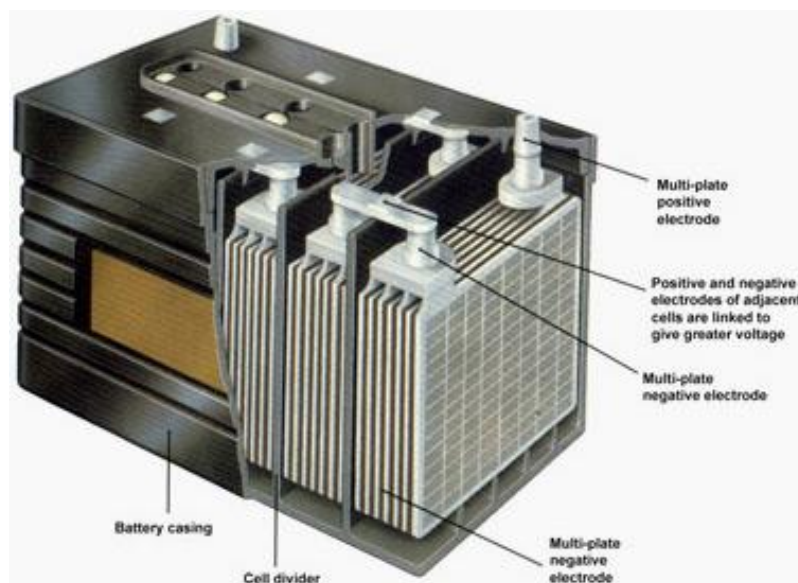

Figure 2: Automotive starter battery composition<sup>2</sup>.

<sup>2</sup> Source: <http://electrical-engineering-portal.com/wp-content/uploads/lead-acid-battery-construction.jpg>

### 2.1.3 Intelligent Battery Sensor (IBS)

To read the data coming from the battery and to share it with the EPM system, a so-called Intelligent Battery Sensor (see Figure 3) is attached to it. The IBS reads the voltage on the electrodes, the current flowing through and the temperature of the battery, processing this information to estimate the SOC for the EPM controllers.

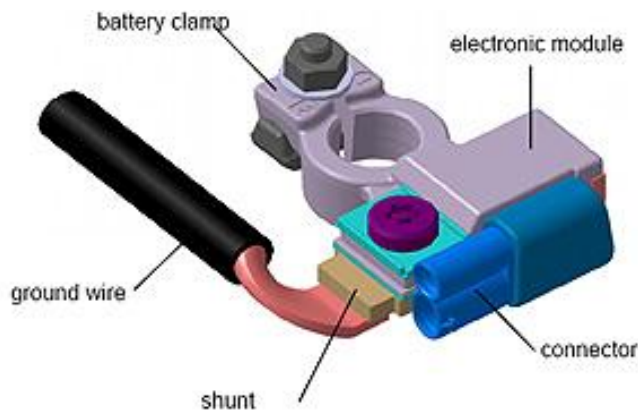

Figure 3: Intelligent Battery Sensor<sup>3</sup>.

The sensor is projected to be compact and easily integrated with the vehicle and the different types of batteries. Therefore it works as a preventive system against battery major failures.

### 2.1.4 Internal Loads

Apart from the starting situation, the vehicle's internal loads are the main consumers of energy, once the car is turned on the generator and the battery work together to supply them. There are plenty of loads present in the system, serving to diverse situations.

These loads are switched on or off depending on the necessity and each one demands a determined current, oscillating the charge consumption.

---

<sup>3</sup> Source: <http://www.atzonline.com/cms/images/f2008-05-093.jpg>

Common electrical loads:

- Head lamps;
- Stereo;
- Cooling fan;
- Break lights;
- EPM control modules;
- Air conditioner.

## 2.2 Embedded Controls

All the components described in the last section are part of the electrical system and each one has a determined function that was already explained.

The 'Energy Power Management' task is to bind everything in a unified working system, changing the vehicle's behavior to guarantee the integrity of the parts and to improve efficiency. There are two control modules embedded that are used to constitute the EPM: the Body Control Module and the Engine Control Module, both of them have plenty of functions, being the EPM just one. Figure 4 shows the controls association.

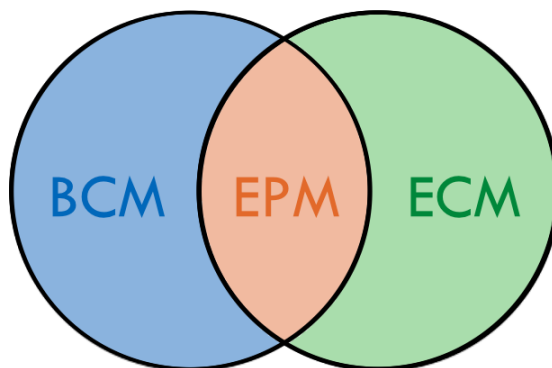

Figure 4: Control modules composing the EPM.

These control modules, owned by the company Adam Opel A.G., are implemented using Matlab - Simulink® with a Real-Time Interface.

## 2.2.1 Body Control Module (BCM)

The Body Control Module is a main controller system responsible for the operation of a series of electronic accessories. A small part of the BCM, related to the generator operational mode, composes the most of the EPM.

The BCM receive data from determined sensors and processes the logical conditions, defining a set point for the generator. This set point is forwarded to the Engine Control Module.

There are different operational modes that can be activated, depending on the hardware installed in the car (starter battery type, secondary battery topology ...) and the activated conditions. The regular modes, in an ordinary vehicle using a Lead-Acid Battery, are:

- Startup: Setting a higher voltage for the generator, tries to recharge the battery just after the auto-start, consuming a significant amount of capacity;
- Head Lamps: Rising the generator voltage to a minimum level, enough to guarantee the required brightness on the vehicle's front lamps;
- HVAC, Wiper, Trailer and BCVR voltage boosts: Different voltage boost modes to supply extra loads active during the driving;
- Fuel Economy (FEM): Reducing the voltage set point and allow the battery to supply the vehicle loads. This mode is often used to reduce the fuel consumption, since there is no current being drained from the vehicle's generator;
- Normal: The voltage on the generator is selected basing on the battery's temperature and State of Charge, focusing on the optimal value to recharge. The normal mode is generally active when there is no heavy loads being used and the FEM can't be activated for some reason;

- Anti-Sulfation: A special mode necessary when using Lead-Acid Batteries, the set point must be raised due to the sulfation behavior when in low charge (see section 3.2.4);
- Recuperation (REC): During driving it's possible to reach what is called a "recuperation event". This event happens when there is still engine movement but the fuel consumption of the vehicle is very low or inexistent. In this case the voltage generated can be increased to charge the battery using the engine rotation remaining, saving fuel. Those events normally last just a few seconds and timing is crucial to get this "free" energy.

The "Recuperation Mode" is the only operational mode not defined by the BCM, since the sample time of this module is 1s and the REC events are very short. Because of that, the Engine Control Module assumes this function, overriding the BCM set point shortly.

## **2.2.2 Engine Control Module (ECM)**

Initially the ECM had the only task of forwarding a reference (coming from the BCM mostly) to the generator, working as a feed-forward strategy. However for efficiency purposes its functions were adapted to bear a better behavior.

This module (which uses a sampling time of 0.1s in the EPM) is responsible for properly converting the generator set point to a voltage difference. The ECM is involved in the closed loop controls (see Figure 5), using the basics control principles of reading, comparing and acting to reach the desired set point.

The ECM has two different control laws, to adapt voltage or current control. It reads the battery data (voltage or current) and processes it to define an action. Unfortunately, the Engine Control Module can only act over the voltage (using the L-Term, explained in the section 2.1.1) on the generator, inducing an indirect current control (see section 5.3.2).

As already said in the section, the Recuperation Mode is the only logical control included inside the ECM, due to the fast response.

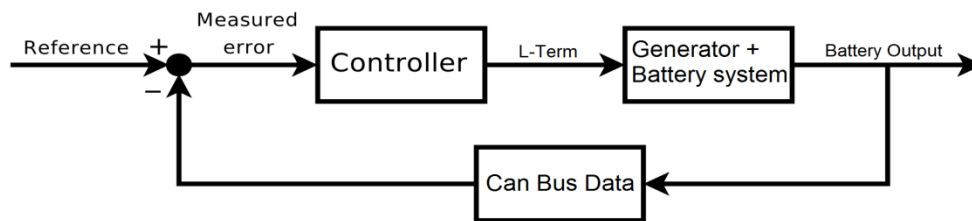

Figure 5: ECM Closed Loop.

### 2.2.3 dSPACE MicroAutoBox

The dSPACE MicroAutoBox is the only component described until here that is not included in a common vehicle, it is used only during the development phase of the control system. Basically what it does is replacing the BCM and the ECM with its own control system.

The main reason for including the dSPACE for developing is that the embedded control modules must be strictly stable and robust, which can't be achieved during starting projects. The BCM and ECM are handled only for authorized employees and every change there must be analyzed by them.

All the controls explained in the next chapters are applied using the dSPACE, simulating both control modules behavior.

## 2.3 Hardware Configuration and Information Flowing

The circuit showing how the generator and the battery are installed inside the vehicle can be seen in Figure 6. The diodes block the current when the voltage in the generator is lower than the battery's, allowing the loads to be supplied by the battery itself.



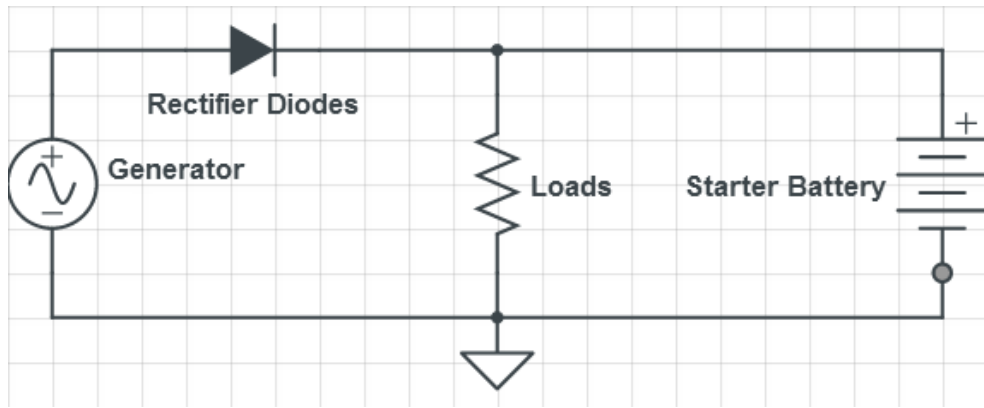

Figure 6: Charging system circuit.

Figure 7 summarizes how the whole charging system interacts with the EPM and how the information flows from component to component.

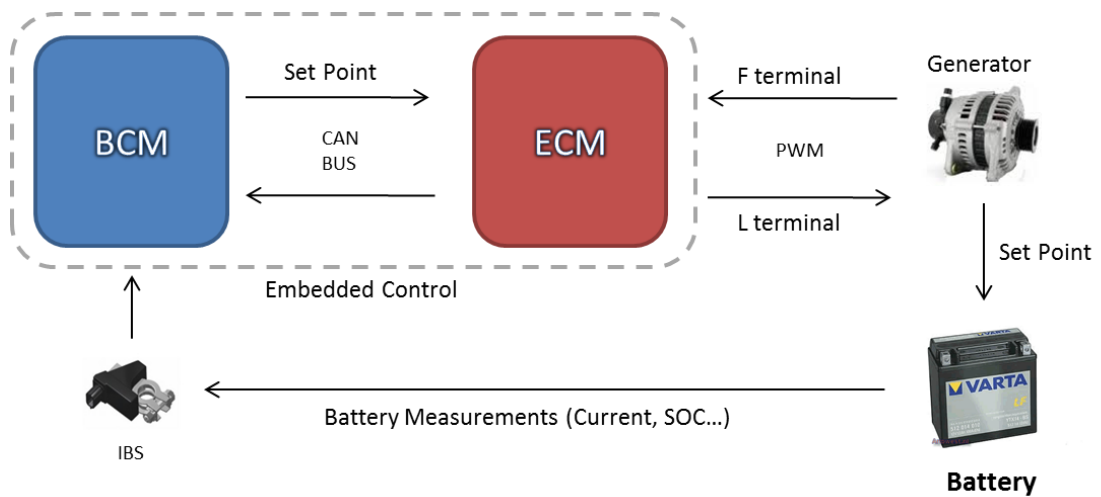

Figure 7: Electrical system's information flow chart.

For the next chapters, the Battery component seen in Figure 7 will be expanded, introducing some new variables and how the battery type inflicts on the vehicle.

## Chapter 3: The Lead-Acid Battery and Vehicle Behavior

Nowadays the Lead-Acid market related to the automotive batteries covers over 85% (see Figure 8) of the vehicles and its sales are around \$30.0 billion annual [5].

The Lead-Acid battery is being used in high scale since a long time because it was the first rechargeable battery created (see section 3.1), opening a large amount of possibilities. As the time passed a lot of improvements were done and the production cost dropped significantly, justifying its popularity.

However, this battery is far from ideal, there are negative points inducing changes in the market and new researches are being done.

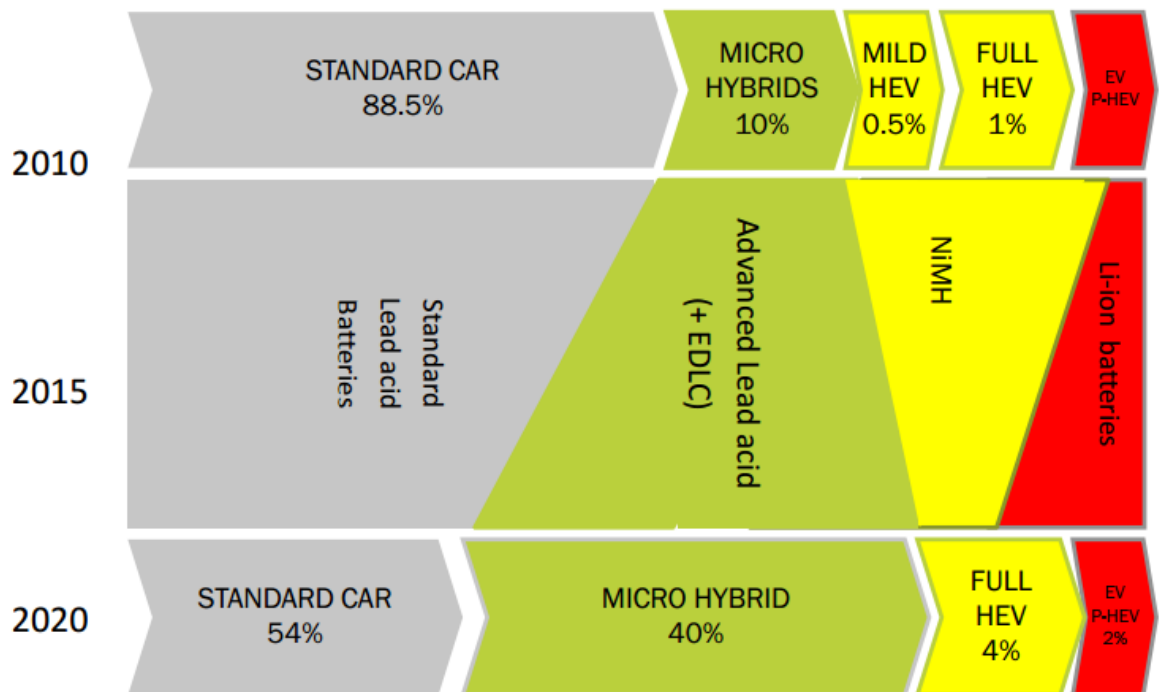

Figure 8: Rechargeable batteries market distribution<sup>4</sup>.

<sup>4</sup> Source: <http://www.rechargebatteries.org/wp-content/uploads/2013/04/Batteries-2012-Avicenne-Energy-Batteries-Market-towards-20251.pdf>

### 3.1 Historical Background

As already said, the Lead-Acid battery was the first rechargeable battery invented. The French scientist Gaston Planté was the name behind its creation during the 19<sup>th</sup> century.

Planté used his chemistry knowledge to project a battery cell capable of store energy when crossed by a reverse current. The materials used in the experiment were two plates of Lead (Pb) immersed in sulfuric acid, therefore naming the “Lead-Acid” those types of batteries [6].

After that, the rechargeable battery started to be heavily used, expanding its usage to different functionalities and starting a new generation of researches in the Lead-Acid area. The flaws attached to this battery started to be avoided with modern technologies, as we have today advanced Lead-Acid batteries with a very low cost.

It is common to find today improved batteries called Flooded Lead-Acid Batteries (FLA), in which the plates are totally submerged in fluid, as well AGM batteries, which are being used by the company Adam Opel A.G. at the moment<sup>5</sup>.

### 3.2 Characteristics and Influence in the Automotive Sector

The Absorbed Glass Mat (AGM) batteries included in the standard vehicles have a very good cost/benefit ratio and they are the major components used by Opel nowadays.

However, this low cost is compensated with drawbacks forced by the battery, holding back some development lines that could be highly explored to reduce fuel consumption and even CO<sub>2</sub> emissions.

Decreasing the CO<sub>2</sub> emissions will be essential for the next years, since the standard for 2020 is 95g/km (according to the “*EU transport white paper*”) and the average currently goes around 126 g/km. Because of these conditions, the price corresponding to the reduction of 1g of CO<sub>2</sub> is almost €100 [8].

---

<sup>5</sup> See Appendix A

There are key characteristics related to the battery that inflict directly in the car effectiveness and sometimes are limiting factors. Unfortunately, some of these features are bonded to the battery's type and can't be avoided.

When compared with new technologies, the AGM Lead-Acid battery possesses several disadvantages, the most important of them are described in the following sections.

### **3.2.1 Weight**

There is a direct relation between fuel consumption and the car weight, which is clear, because the heavier the vehicle is, the harder must the motor work. It is known that for every 100kg of weight reduced, the fuel consumption decreases by 0.25 l/km, resulting in about 7 g/km of CO<sub>2</sub> saved [9].

This is a negative point for Lead-Acid based batteries due the fact that they are much heavier than other types of batteries, holding the double weight for the same capacity.

An average 80Ah AGM battery weights about 24kg. That value could be reduced to 12kg with another topology, implying already a gain of 0.84 g of CO<sub>2</sub>, €84 for each car, doing the math.

### **3.2.2 Charge Acceptance**

The charge acceptance represents how much current the battery is able to receive during the charging periods. The generator is capable of supplying a determined amount of current to this process, and the higher is the charging acceptance, the faster the battery will be charged.

For Lead-Acid batteries this characteristic is inversely proportional to the State of Charge, the SoC increasing reduces the amount of current going through the battery. For aged batteries this factor turns so influent that it becomes impossible to fully charge it again, because with approximately 85% of SoC the charge acceptance is already insignificant.

Figure 9 displays a Lead-Acid AGM battery during a charging and discharging process, decreasing the State of Charge. It is possible to see the charging acceptance growing as the capacity (Ah) goes down.

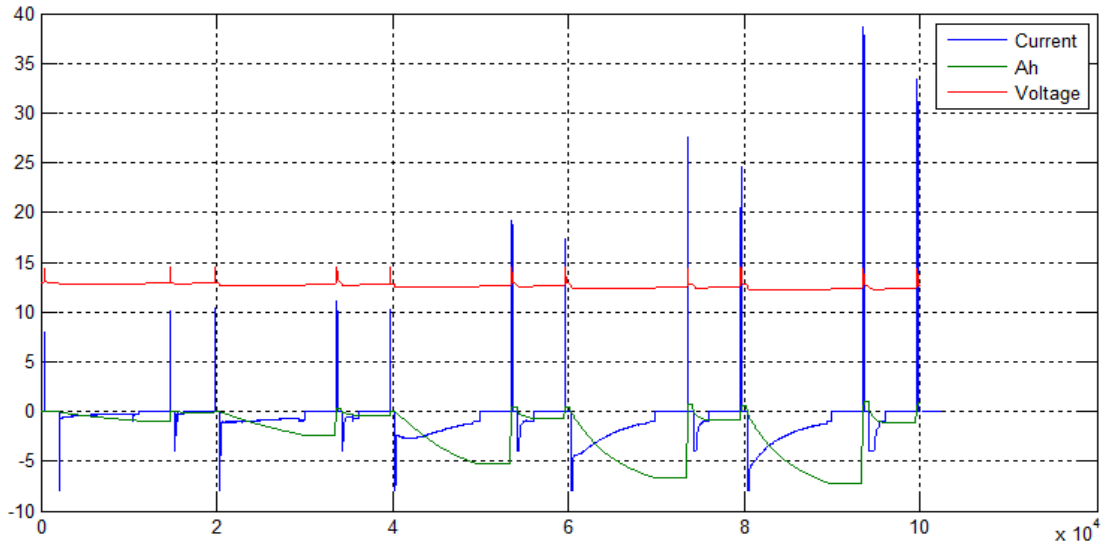

Figure 9: Charge capacity of a Lead-Acid AGM battery.

### 3.2.3 Environment Impact

As said in the section 3.1, the standard battery included in the vehicles is composed for Lead plates submerged in sulfuric acid. Both of these components are extremely dangerous to the environment.

The acid, which has PH about 1.5, is very corrosive and works as a solvent to lead particles. The lead, by itself, is a toxic material that can damage the brain, the kidneys and the hearing sense; it also generates a great amount of diseases.

Though the recycling system for these batteries works very well, about 10% of the old ones do not return to the manufacturers, ending up as a possible threat [10].

### 3.2.4 Behavior with Low Charge

When a Lead-Acid battery goes to a low SoC status, it is common to see a problem called *Sulfation*. This often happens when the battery is supporting heavy loads and the generator doesn't have time to charge it again.

The *sulfation* issue occurs when the lead sulfate crystalizes and deposits itself on the negative plates (see Figure 10). The result of that is the formation of large crystals, raising the internal resistance and reducing the charge acceptance

This problem forces a special mode development (see section 2.2.1) to avoid bad situations.

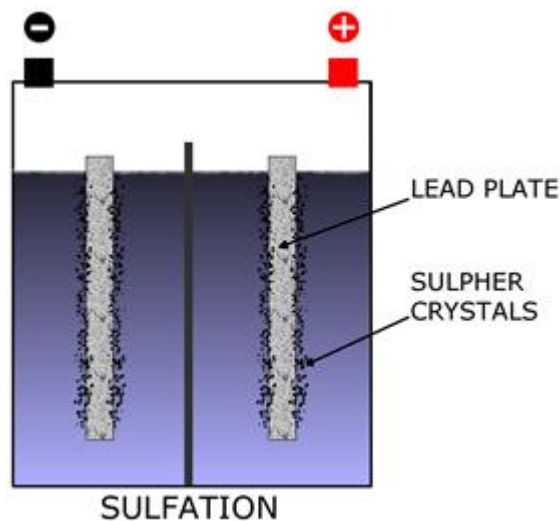

Figure 10: Sulfation on battery's plates<sup>6</sup>.

### 3.3 Possible Improvements

With the current technologies, there is a plenty of room for improvements involving batteries' issues. The researches of new chemistries are taking more and more space inside the companies that are trying to gain a single gram of CO<sub>2</sub> without adding extra costs.

<sup>6</sup> Source: <http://www.dsi.com.np/desulfator/images/battery1.jpg>

The most competitive battery still is a Lead-Acid due the historical reasons; however, for the future more will be necessary, besides, others topologies are giving better expectations.

Lithium based batteries won a lot of attention because of their good behavior when compared to the lead-acid structures. They are superior in almost all of characteristics; unfortunately also the costs are higher.

Some options are shown in Figure 11, where the voltage curve is compared to the state of charge. Each battery has its own inherent characteristics and is being studied, which includes the voltage behavior during the high and low charge situations.

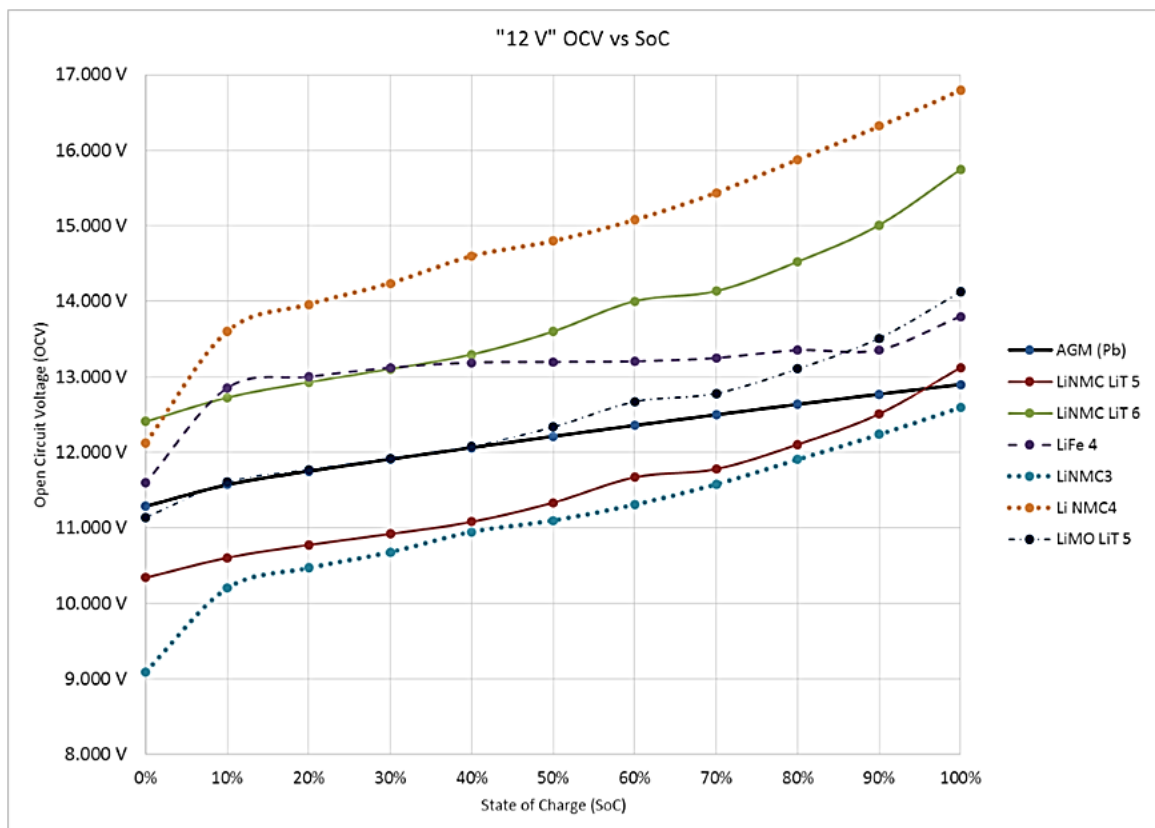

Figure 11: Comparing SoC behavior in different types of batteries.

The chart presented in the Figure 11 is very important to define which battery will be picked, depending on the topology selected and the system equipped. Although this graphic is not related to the battery effectiveness, it inflicts in the final choice. Some possible strategies include high voltages with the power decreasing during the battery's use, while others prefer average voltage with constant power during almost the whole SoC's range.

The purple line represents a Lithium-Iron Phosphate battery curve ( $\text{LiFePO}_4$ ), which will be detailed in the next chapter.



## Chapter 4: Using a Lithium-Iron Phosphate Starter Battery

The LiFePO<sub>4</sub> starter battery is a recent technology (1970s) developed in the USA, being commercialized since the early 1990s. As one of the many lithium-based batteries, it uses LiFePO<sub>4</sub> for the positive plates and graphite for the negative; both submerged in a lithium salt compound (see Figure 12).

When equipped as a starter battery, it brings a large amount of improvements to the system (see section 4.1), with significant changes in the charging system's behavior.

Each cell composing this Lithium-Ion battery has 3.3V and they are attached together in a group of 4, resulting in a 13.2V battery, a value already higher than a 6 cells Lead-Acid energy source.

Using this component allow us to explore new strategies to save fuel and battery energy, which was not possible with a standard system configuration (see section 4.2).

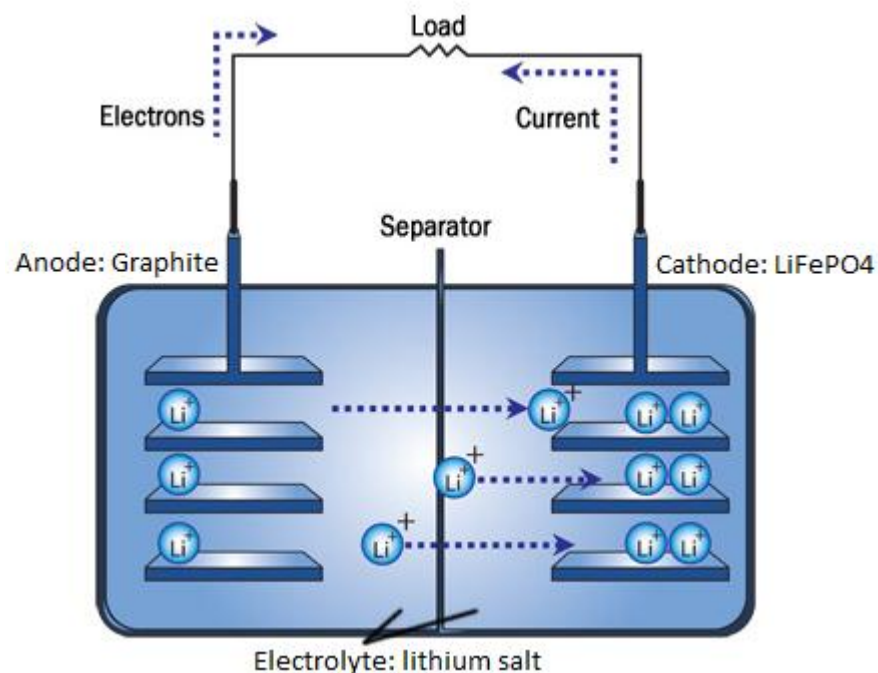

Figure 12: Lithium Iron Phosphate Battery discharging<sup>7</sup>

<sup>7</sup> Source: <http://s.hswstatic.com/gif/lithium-ion-battery-6.jpg>

## 4.1 Characteristics and Potential

Going for a direct comparison with a Lead-Acid AGM battery and using the characteristics explained in section 3.2 as a guide, we can show the Lithium-Iron Phosphate main features in Table 1

Lithium-ion batteries are much lighter than the standard components, which can be converted directly to costs saving (see section 3.2.1). Besides, their chemistry (iron, lithium and graphite) is environmentally friendly, avoiding possible ecological risks.

The current acceptance related to this battery is a very important factor; the low internal resistance allows a higher current peak and is not affected by the state of charge, which means it is possible to quickly recharge it with a high current even when the battery is almost with its full capacity. Moreover, the current acceptance is so good that a regular generator cannot supply more current to this process, since the Li-Ion battery drains all of it. Figure 13 shows a charging/discharging process where the absorbed current is saturated in 100A for the whole process because of the generator.

Another point strongly explored in this battery is its behavior during cycling (charging and discharging). The Lithium chemistry normally is not affected by deep discharging events, permitting the battery to support the loads more often without harm. Meanwhile, a Lead-Acid component suffers with sulfation and permanent damage problems, being unable to return to its full capacity.

Apart from the positive points, there is only one weakness holding back this topology. The temperature is a heavy noise in the system, it affects drastically the batteries behavior and because of that, measurements are being done with LiFePO<sub>4</sub> components in very low temperatures (-30 °C), where it is expected to have a bad operational situation.

Looking closely to the Figure 11 we can see that the “SoC vs OCV” curve related to the Lithium-Iron Phosphate is very high and flat from 10% to 90% of SoC, deviating from the AGM track. This situation guarantee almost full power from the battery until it is totally discharged, however, it makes very hard to estimate the “State of Charge” basing only in the “Open Circuit Voltage”.

Characteristics	Lead-Acid (AGM)	Lithium-Ion (LiFePo4)
Average Internal Impedance - DC (mΩ)	30	5
Weight (kg)	24	12
Capacity (Ah)	80	80
Charging/Discharging Capacity	About 25% of the SoC	Over 50% of the SoC
Current Acceptance (A)	See Figure 9	See Figure 13
Cold Cranking at -18°C (CCA)	800	830
Low Charge Behavior (50% SOC)	Sulfation	-
Open Circuit Voltage vs SOC	See Figure 11 (AGM)	See Figure 11 (LiFe4)
Operating Temperature (°C)	-30°C to 50°C	-30°C to 50°C
Specific Energy ( $\frac{W.h}{kg}$   $\frac{W.h}{L}$ )	40   87	88   96
Number of Cycles (to 50%)	600	4x Lead-Acid cycles*

\*According to the supplier.

• Positive Results.

• Negative Results.

Table 1: Lead-Acid AGM and Lithium-Ion (LiFePO4) characteristics

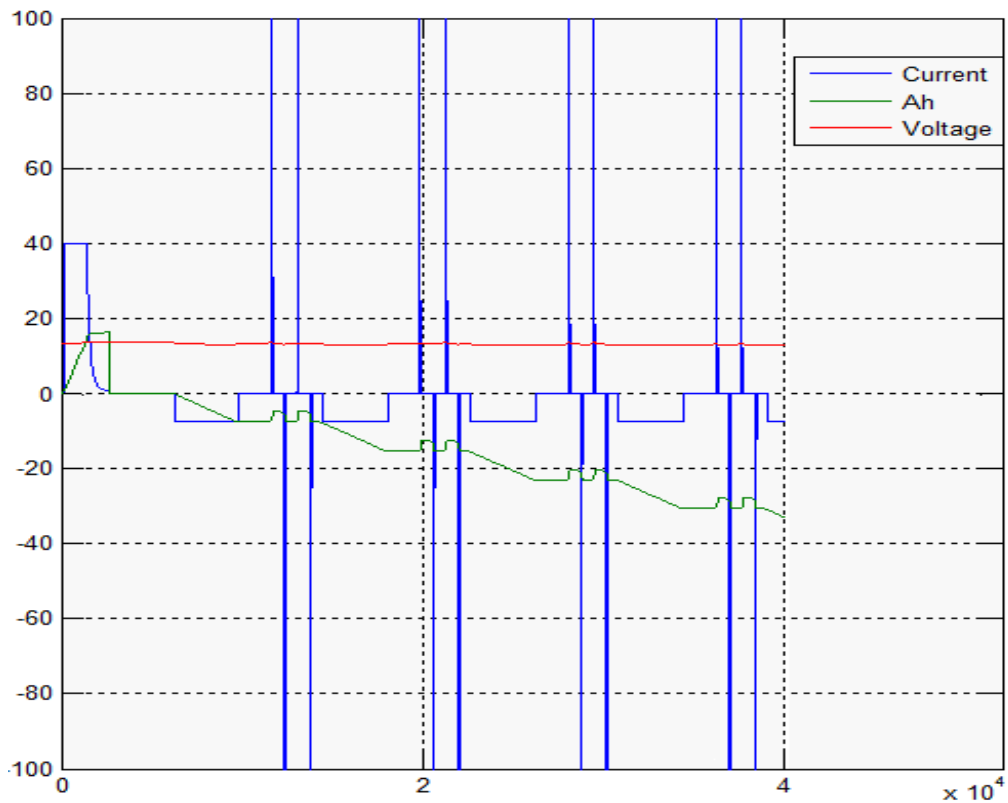

Figure 13: Charge capacity of a LiFePO4 battery.

## 4.2 Objective and New Features

With both batteries presented and compared, it is clear that there is still a lot of range to improvements once we replace a standard Lead-Acid battery for a Lithium-Iron Phosphate.

The main task described in chapter 5 consists in developing proper controls capable of integrate the new battery in the vehicle, exploring the diverse qualities to upgrade the operational modes and adding new features to the car, trying to compensate the extra costs. As a final objective, we expect to obtain results capable of validate this application to future production.

The new features possible with Li-Ion battery:

- Removal of some voltage boost modes: The battery's average voltage is already higher, being unnecessary raising the generator during the usage of heavy loads;
- Renovation of Fuel Economy Mode: The high charge acceptance allows the generator to quickly recharge the battery; because of that it is possible to use the battery for supplying the loads during long periods without discharging it too much. The new FEM works together with the Recuperation Mode to hold the battery's charge;
- More energy absorbed during Recuperation Mode: Looking at the Figure 13 and comparing to the Figure 9, we can estimate that it is possible to get at least 4 times the energy in the same "REC" event when using lithium based topologies;
- Reducing starting time and vibration: A LiFePO<sub>4</sub> battery is more stable and less sensitive to voltage drops, which guarantee a better starting behavior, reducing the cranking time and vehicle vibrations.

## 4.3 Necessary Changes

To integrate the lithium battery it is necessary adapting the hardware to bear the new system, as well to include upgraded controls in the software capable of explore the new features mentioned before.

### 4.3.1 Hardware

Figure 14 shows the configuration for a new hardware integrating the Li-Ion battery. There are some main differences when we compare it with Figure 7 (see section 2.3).

It is necessary a new Intelligent Battery Sensor (IBS) capable of reading the data related to the LiFePO4 component. This sensor must be able to estimate the SoC based on the battery's temperature and OCV.

Looking back to section 2.2.3, we need to attach to the development system a Dspace controller instead of using the ECM/BCM modules, which has the software adapted inside.

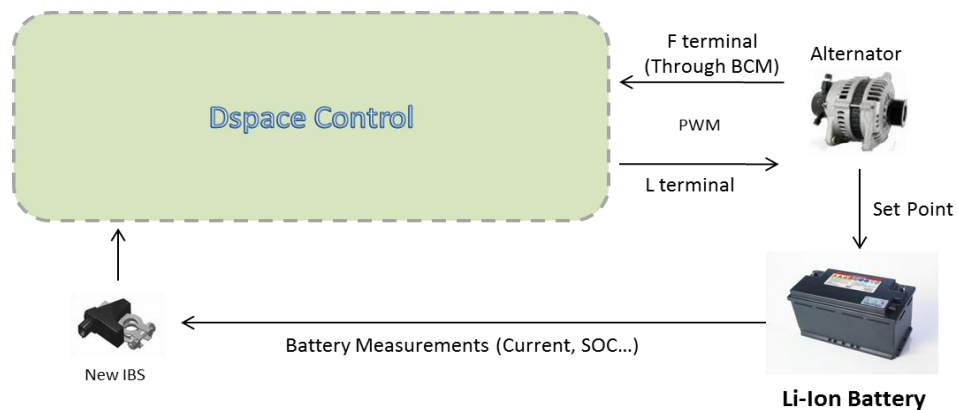

Figure 14: New hardware adapted to the Li-Ion battery

These changes will be applied in an adapted *Astra GTC*, a test vehicle destined to practical analysis<sup>8</sup>.

<sup>8</sup> Due to internal norms, the test vehicle can't be shown in this document

### 4.3.2 Software

The software inside the Dspace MicroAutobox overrides the ECM and BCM (see section 2.2) controllers, so, it assumes all the logical and closed loops functionalities.

Table 2 shows which operational modes will be necessary for the new structure, mimicking the BCM requisites.

<i>Operational Modes</i>	<i>Lead-Acid Battery</i>	<i>Lithium-Ion Battery</i>
<b>Startup</b>	<b>Yes</b>	<b>Removed</b>
<b>Headlamps</b>	<b>Yes</b>	<b>Yes</b>
<b>HVAC voltage boost</b>	<b>Yes</b>	<b>Yes (Not implemented)</b>
<b>Wiper voltage boost</b>	<b>Yes</b>	<b>Removed</b>
<b>Trailer voltage boost</b>	<b>Yes</b>	<b>Removed</b>
<b>Fuel Economy</b>	<b>Yes</b>	<b>Yes</b>
<b>BCVR</b>	<b>Yes</b>	<b>Removed (linked to normal mode)</b>
<b>Normal</b>	<b>Yes</b>	<b>Yes</b>
<b>Anti-Sulfation</b>	<b>Yes</b>	<b>Removed</b>
<b>Recuperation</b>	<b>Yes</b>	<b>Yes</b>

Table 2: Lithium-Ion operational modes

ECM tasks will be simulated inside the software as well, however, this “module” will pass through a substantial reformulation of control laws and closed-loop structure. An important step will be to accelerate the sampling time of the controller from 1s to 0.1s, aiming to have faster responses.

## Chapter 5: Building the Controls

Following the standards maintained by the Adam Opel Company, the controls developed for the new EPM software are based on Matlab - Simulink® models running through a real-time interface library. These models are compiled and exported to the dSpace Interface (see section 5.4), responsible for the data exchange between the computer and the vehicle. It is important to emphasize that the controls aren't embedded in the vehicle during the development phase; instead, a laptop shares the data with the car.

### 5.1 Simplified Simulink Structure

The Simulink model is subdivided in three blocks (as seen in Figure 15), each one with a particular sample time and a well-defined function:

- **BUS Reader** (sampling each 12.5ms): This block's function, as the name suggests, is to read all the data available coming from the sensors (vehicle's sensors or IBS). Those data are transmitted to the next blocks for further decisions. Some estimations are done inside this block as well, however, just minor issues; because the sampling cannot be overloaded by extra tasks.
- **dSpace Body Control Module** (sampling each 1s): After receiving the sensors' data from the "BUS Reader", this block begins to take decisions based on logical operations and the received values. The operational modes of the system depend on these decisions and the set point for the generator is selected using matching tables.

- Dspace Engine Control Module (sampling each 0.1s): The proper actuation in the system is controlled by this block. It receives a desired set point and, using a closed-loop control, communicates with the generator through the L-Term signal.

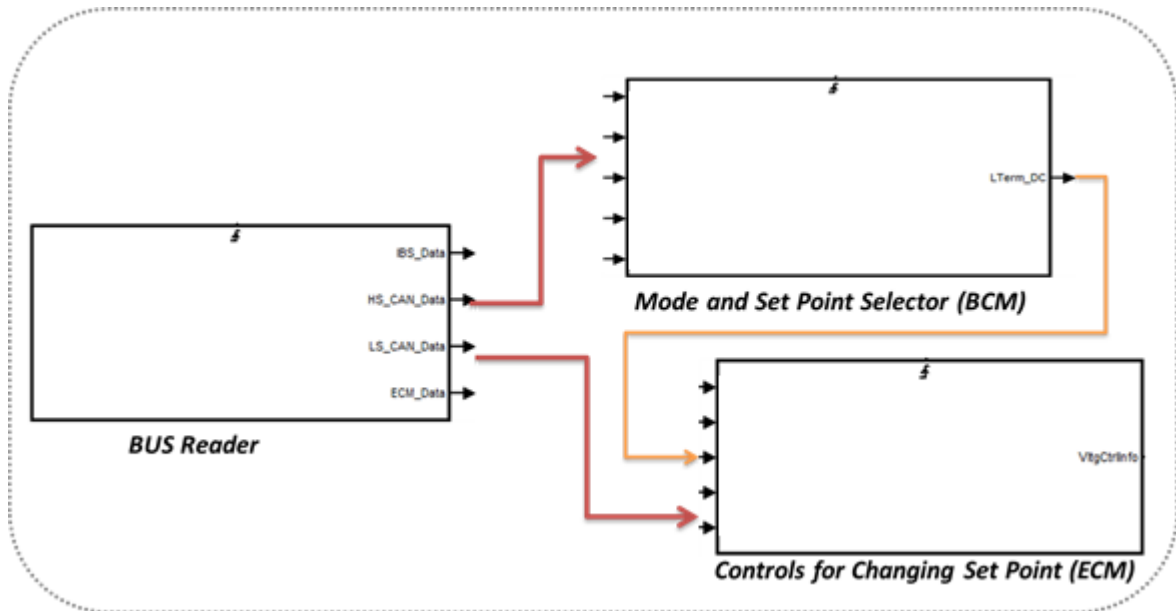

Figure 15: Simulink structure of the control modules

## 5.2 Logical Controls and Operating Modes (BCM)

Our lithium-ion battery has a particular charging table responsible for selecting which voltage will be chosen as a set point. This table is temperature dependent and defines the optimal value to reload, ensuring that the component won't be overcharged. The lithium-iron phosphate structure is very sensitive and could be permanently damaged under a long time in high voltage.

Figure 16 presents how the charging voltage change depends on temperature. These values are applied normally when we just want to charge the battery, not aiming for a specific operational point.



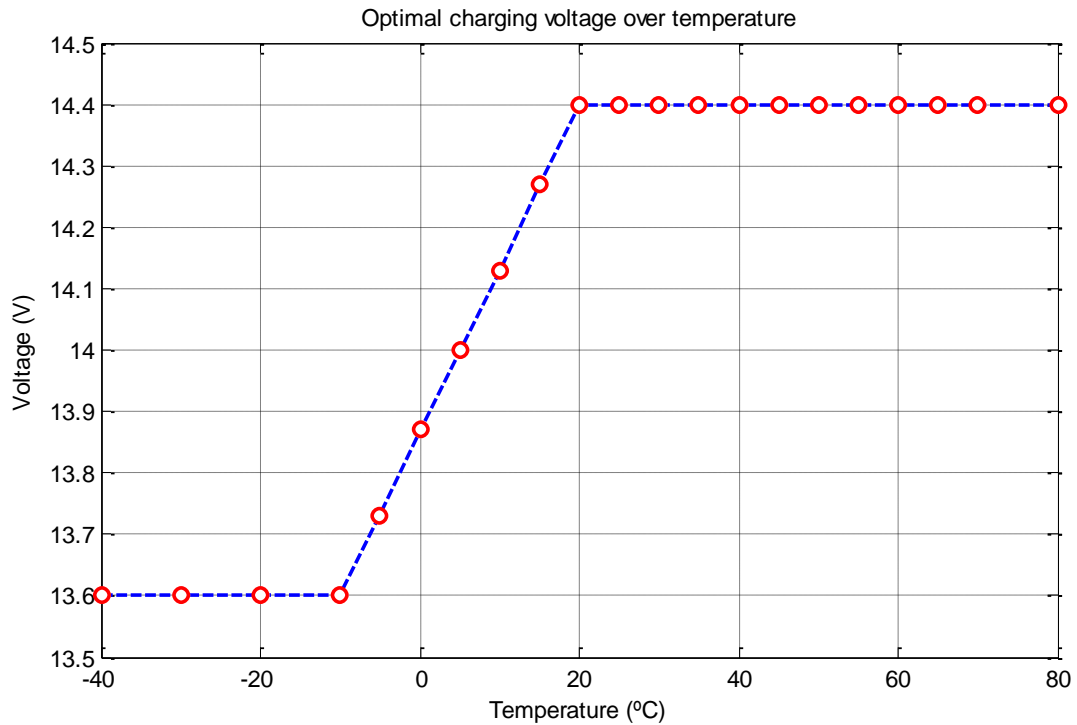

Figure 16: Optimal charging voltage

Different from the ECM, the BCM can output a set point in voltage or current. Normally, voltage references are used during charging and discharging phases, while current set points are used to hold the battery in a determined SoC.

For the new topology, the generator is limited by voltage values oscillating from 12.3V up to 15.5V. The current values aren't limited, that is explained in section 5.3.2.

According to Table 2, there are several operational modes responsible for selecting the desired reference for the generator. These modes, explained in next sections, don't have a fixed value; they can switch set points according to the respective mode's logical operations.

### **5.2.1 Normal Mode**

The normal mode is turned on as the “last choice”. We activate it when there are no extra loads attached and the battery is not requested as a load supplier, basically, it is activated by elimination, since no other mode is enabled.

During this operation the generator is switched on and feeds everything, which includes the electrical components and the battery.

The voltage selected for the generator follows Figure 16 until the battery is over 80% of State of Charge, after that the voltage is replaced by a current set point of 0, implying that the battery won't be charged neither discharged (BCVR mode function).

The main reason for this choice is that the LiFePo4 batteries are harmed when working in this area, since individual cells don't have the same internal voltage and it is possible to overcharge them.

### **5.2.2 Head Lamps Mode**

The vehicle's head lamps by regulation must always work with a voltage over 13.5V to avoid a blinking situation. So, every time the head lamps are turned on, this mode should be active.

This mode can work in two different manners:

- Use the value from the optimal charging table (Figure 16) and request full support from the generator;
- Set the minimum value of 13.5V and try to decrease the fuel consumption;

The second option is chosen when the Fuel Economy Mode (see next section) was enabled before the head lamp being switched on. Normally holding the reference at the minimum value cannot avoid fuel consumption, however, in case we need to go back to the FEM, we are closer from a lower set point and can respond faster.

### 5.2.3 Fuel Economy Mode

The FEM is often appointed as the most important operational mode of the charging system, since it brings direct advantages to the company: reducing fuel consumption and CO<sub>2</sub> emissions.

It consists in decreasing the voltage on the generator (switching off) and let the battery support the system. There are some conditions that must be satisfied to enable this mode and guarantee the battery's health:

- SoC must be higher than 55%;
- The battery's temperature must be higher than 0 °C and lower than 45 °C;
- The voltage read in the terminals must be higher than 12.1V;
- No other vehicle's controller must be asking for activation of the generator;
- Once in FEM, the SoC necessary to leave the mode is 50% (hysteresis).

This mode presents different behaviors depending on the battery's SoC:

- When the battery is over 60% of charge: set a lower voltage to use only the battery as a load supplier;
- When the battery is under 60% of charge: stop discharging the battery and change to current control with set point 0, using the generator to support the loads and keeping the SoC constant.

The challenge about developing this mode comes when we need to define a voltage reference for the discharging phase. The Lead-Acid system used a fixed 12.3V value, which is not efficient for our LiFePO<sub>4</sub> for certain reasons:

- The Lithium-Ion Battery has a higher voltage: using 12.3V would work to switch off the generator, although it would create an undesired “dead zone” of about 1V in average (the Li-Ion battery has 13.2V nominal, but the voltage is higher when it’s powered by the generator);
- Recuperation events: these events are very short and they need the faster possible response, so, the closer we are from a charging voltage set point, the best we will get this free energy;

The solution found to solve this issue was to dynamically change the reference after reading the battery’s terminals, using the following strategy:

$$\text{FEM-SP} = \min(13, \text{Battery\_Voltage} - 0.2)$$

The “min” function is there because we want to go fast to 13V and then slowly decrease the set point. If we used only the “Battery\_Voltage – 0.2” configuration, every second (sample time) we would decrease only 0.2V, slowing too much the system.

#### **5.2.4 Recuperation Mode**

This mode is not constant; it is only activated during the brief periods of the “REC” events. This is the only mode not defined by the BCM (it is only described here for a better understanding), instead, the ECM switch on this mode in a faster rate.

The Recuperation Mode is a way to recharge the battery without using extra fuel to boost the generator. It works raising the voltage during the FEM, when some conditions are satisfied.

These conditions, converted in logical operations for the software, occur when the vehicle is in situations where the gas pedal is not being used: breaking, going downhill or decelerating.

The strategy used in the software is:

- The gas pedal is not being pressed OR there is no fuel consumption;
- The battery's temperature is under 45 °C, as a safety measure;
- Vehicle speed is over 10 km/h;
- The engine speed is over 1100 rpm: This value guarantee that the engine rotation is enough to raise the voltage even without fuel being injected.

Moreover, there are two exceptional situations where we need to consider the activation or deactivation of the REC mode:

- Gear downshift: During the gear downshift we press the clutch pedal and the engine speed goes under 1100 rpm, which is a condition to leave the recuperation. However, we are still decelerating and we don't want to interrupt the REC event. So, the new condition for the engine speed is: "if engine speed < 1100 for more than a second, leave the mode". This works well because normally changing the gears are very fast events.
- Gear upshift: Every time we upshift the gear we release the gas pedal, so, if the engine speed is slightly above 1100, we would activate the Recuperation Mode. This is undesirable because we are in an accelerating situation, spending fuel. The solution for that is looking at the derivate of the speeding profile, if it is positive, we don't activate the REC event.

The set points for recuperation mode are based in the nominal values presented in the Figure 16.

### 5.3 Closed Loop Controls (ECM)

The closed-loop controls follow the same structure presented in Figure 5, where the controls could be based in voltage or current references. Independent from which control is in use, the output will always be a PWM signal going to the generator (*L-Term*), defining its voltage.

Because of that restriction, current control cannot convert current error in a proportional set point. So, this control works in an indirect form, doing small steps in the voltage to reach current values.

Due the fact that we have two controllers switching (see Figure 17), it is necessary that both communicate with each other to avoid one of them to lose their track.

The voltage controls for the Lithium-Iron Phosphate are totally different when compared with a Lead-Acid topology. In the old system the speed was not a requirement and the controls were based on fixed step integration, ignoring the magnitude of the errors. Now, since lithium-ion batteries are much more sensitive, we want a faster response during “REC” event.

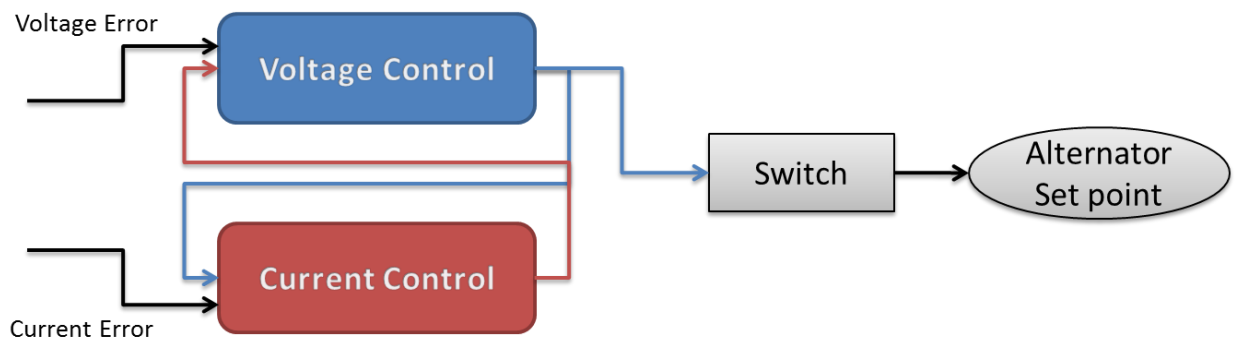

Figure 17: Control switching structure

### 5.3.1 Voltage Control

The new voltage control is now based on a PI controller with several attachments, Figure 18 shows how the whole system is structured.

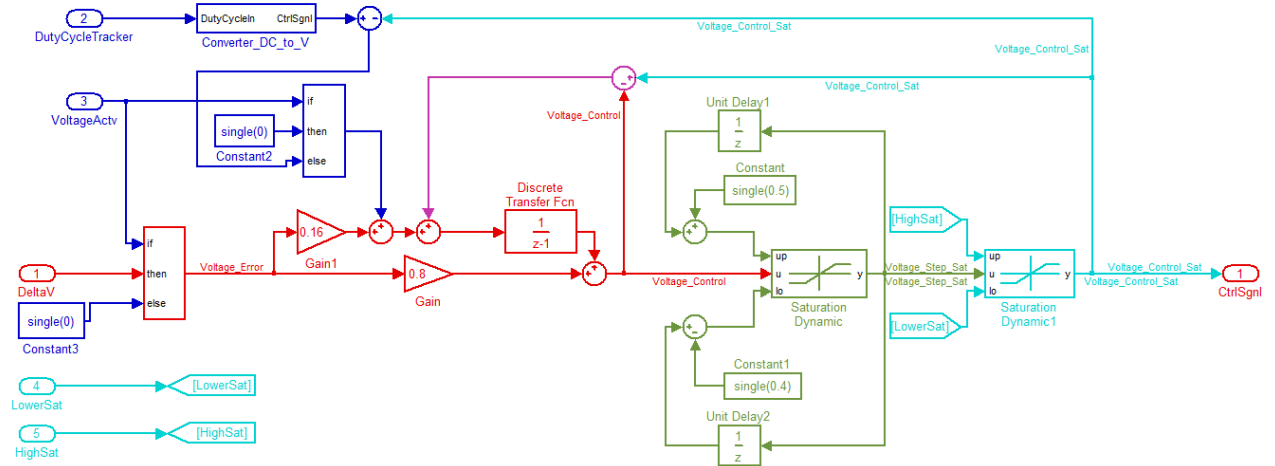

Figure 18: Voltage control structure

The PI controller (red lines in the Figure 18) was projected using the Root Locus technique, where the model was obtained by analyzing its step response (see Figure 19):

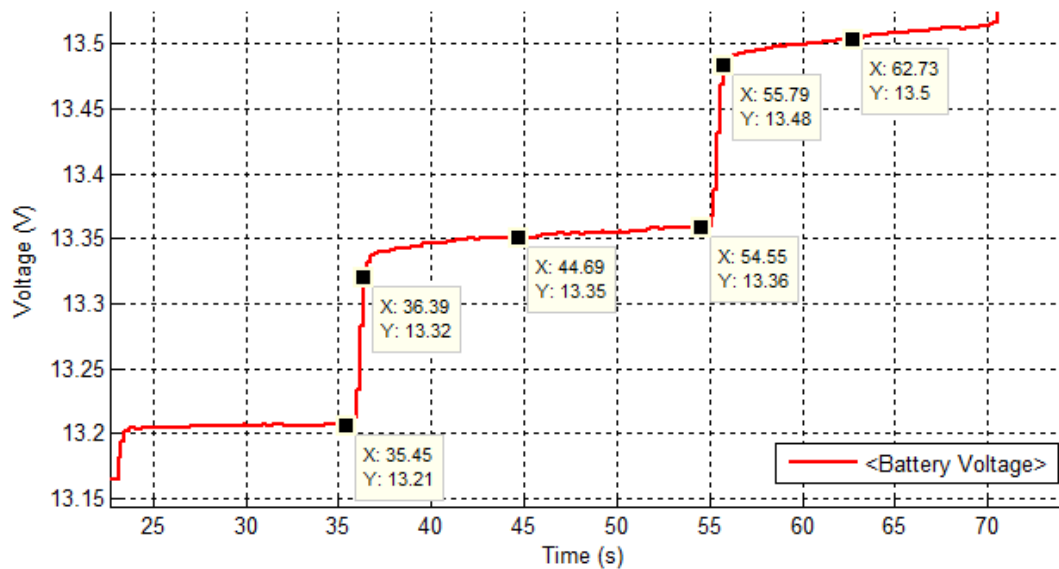

Figure 19: Step response of the system

Knowing that each step had the value of 0.28V, we could estimate the plant as a transfer function:

$$G = \frac{0.5}{1.3s+1}$$

Due to battery restrictions, the system can't be significantly accelerated and it is limited to the regular battery behavior. Moreover, the battery/generator system is very robust to external noises, which mean we don't need to quickly reject them. The main features desired to the control, in this case, are: No overshoots, closed-loop speed at least equal to the plant's speed and follow the reference without static error.

With that in mind, the final controller developed and adjusted during tests was:

$$C_d = 0.8 + \frac{0.16}{z-1}$$

There are two saturations attached to the structure:

- Slew rate (green lines in the Figure 18): The generator voltage variation is limited in 2V per second. During the tests that value was increased to 5V per second without any drawbacks.
- Maximum and minimum values (light blue lines in the Figure 18): As already explained, the generator only works in a range from 12.3V up to 15.5V; because of that, the controls must be limited to not damage the components.

To avoid windup problems related to these saturations, the control structure is equipped with an anti-windup technique (purple lines in the Figure 18). Anti-windup strategies are strongly applied in problems involving saturated systems to reduce eventual overshoots. It works as follows:

Once the system is saturated, the cumulative integral error would increase indefinitely, because controls can never reach the desired set point. To prevent this error to rise endlessly, the anti-windup controller subtracts the desired output value



from the value after saturation, adding this result to the integrator cumulative sum. As an effect we have:

- If the system is not saturated: The subtraction's result would be 0, not affecting the integrator inside the closed-loop;
- If the system is saturated: A negative value will rise after the subtraction, which will be summed to the integrator. This forces the decrement of the integrator cumulative value and avoids possible peaks.

The controller still counts with a tracker structure (blue lines in the Figure 18), responsible for guiding the voltage control when we are working in current mode.

In the end, this control transforms a voltage error in an output signal. After that, it converts this voltage output into a PWM percent signal, which is sent to the generator.

### 5.3.2 Current Control

Current control is much simpler than voltage's, as can be seen in Figure 20. Since we cannot convert the current error into a voltage value<sup>9</sup>, our only option is to use fixed step integration, as it was with the Lead-Acid system.

Step by step, that is how it works:

- If the absolute value of current error is lower than 1, it is summed 0 to the integrator's value;
- Else: the signal of the error defines if it will be added or subtracted 0.05 from the integrator's value;

---

<sup>9</sup> The internal resistance of the battery is variable and cannot be precisely used for applying the ohm's law. Researches must be done to allow that.



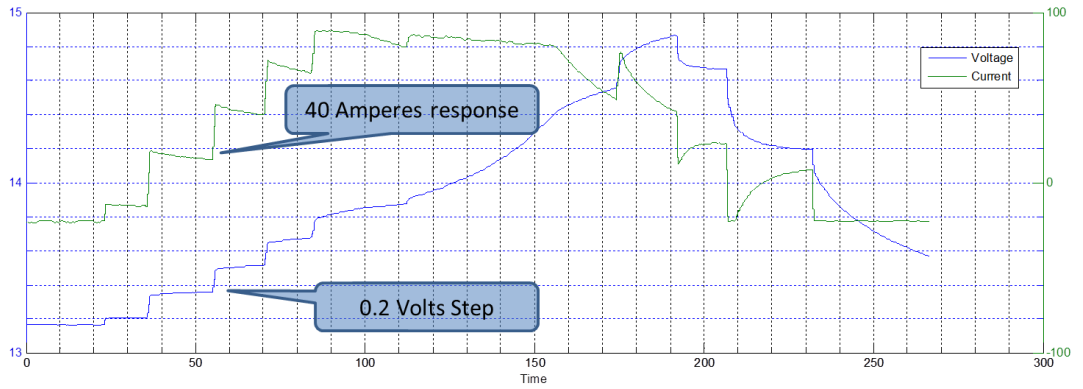

Figure 21: Current response to voltage step

## 5.4 dSPACE Interface

All the measurements and monitoring of the system are done through the dSPACE software. Every variable that we want to watch is added to an interface, where we can see what is happening.

Figure 22 shows the interface used to see the controls working, as well to make the recording of the validation tests realized.

The validation tests and the measurements of the controls' response during driving are presented in the next chapter.

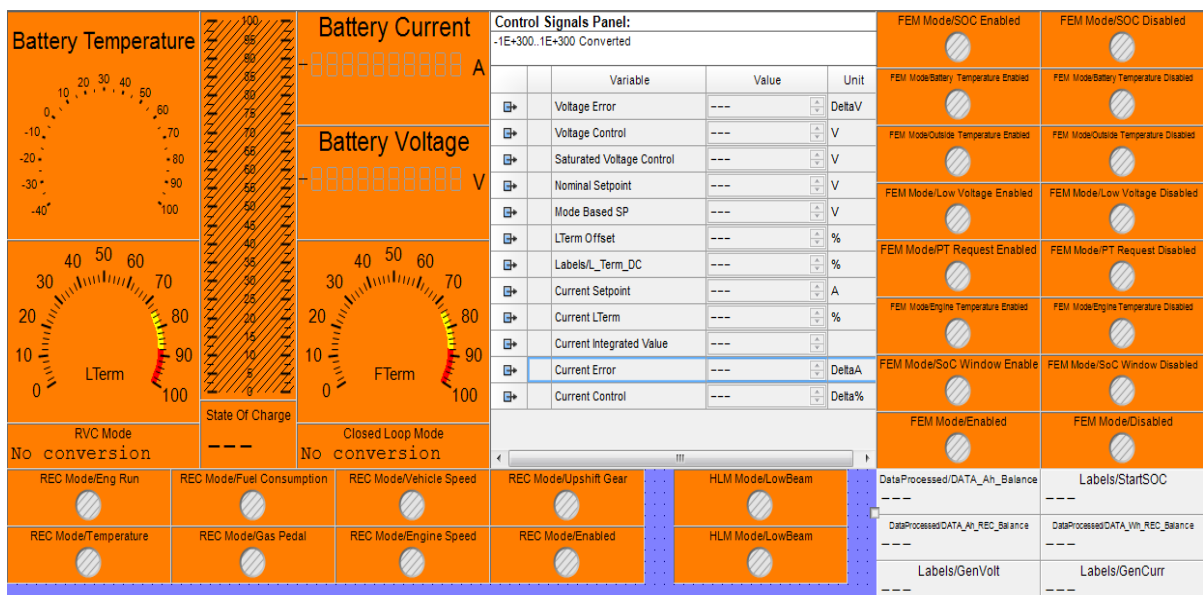

Figure 22: Dspace Interface

## Chapter 6: Measurements, Validation Tests and Results

To study the behavior of the LiFePO<sub>4</sub> system and obtain results to compare the different batteries it is necessary to perform validation tests. These tests are based on different driving profiles and conditions, where data is collected and compared.

Realizing validation tests it is important to verify controls and if they are following the previous specifications established during the development phase. Besides, from the point of view of the company, these results are crucial for further decisions about maintain this kind of topology or not.

The main test profile defined as a pattern is the *WLTP*<sup>10</sup> where it is measured fuel consumption and energy spent. Moreover, extra measurements are important to monitor several variables. For that real driving and starting behavior tests are conducted.

### 6.1 Real Driving Measurements

During driving performances, control's specifications are tested, together with the behavior of the vehicle equipping a lithium-ion starter battery.

Figure 23 shows the reference changing three times on a regular driving on roadway:

- It is possible to see, in first instance, the control with FEM activated, where the set point is hold 0.2 under the battery's voltage. Controls are saturated in this case because the generator is not responsible for discharging phases, depending on the loads to consume the battery's energy;
- Later on, the operational mode is changed to head lamp mode. Here is important to emphasize that there is no overshoot in the transition from FEM to HL mode, which proves the smooth operation of the controllers in

---

<sup>10</sup> See Appendix B

combination with the anti-windup strategy. The reference is followed perfectly in this case; however, in cases of heavy loads switched on, the generator is not capable of supply enough energy to reach 13.5V, which is a problem to be solved in the future;

- A REC event can be seen as well, and again there are no peaks or instability. Figure 24 shows in details the recuperation mode in operation, where it is possible to see the fast response and high current flowing to the battery.

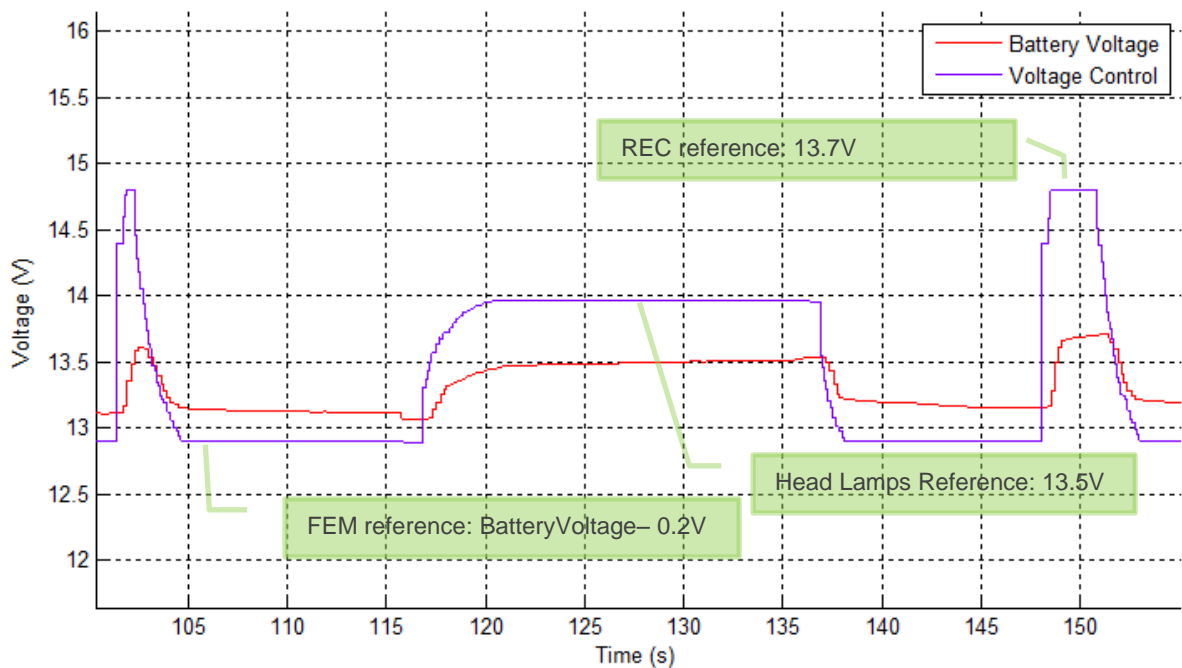

Figure 23: Reference changing during driving test

After analyzing recuperation events in real measurements, we can validate the expectations described in section 4. LiFePO4 batteries are able to bear a huge amount of current during charging, about four times more than a regularly operated Lead-Acid Battery, gaining significant charge with free energy.

Besides, with the new control strategy, activating “REC” events is a lot faster, taking only half a second to start reloading the lithium battery.

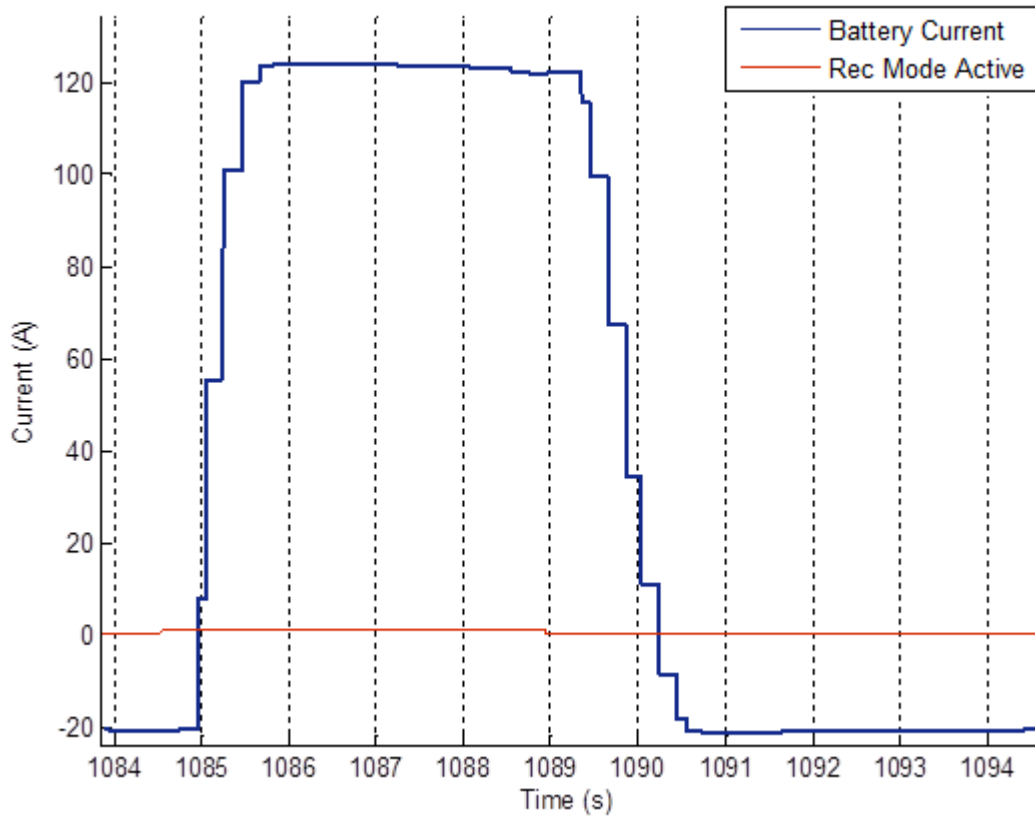

Figure 24: Recuperation event

## 6.2 WLTP Validation Test

As the main validation test running nowadays between the automotive companies, the WLTP Validation Test is a driving pattern with specific conditions that must be followed to guarantee the good performance of the vehicles.

Appendix B brings more details about the WLTP pattern, including a chart of the measurement realized. Since the test is very long and connects too many variables together it is hard to show all the information in a plot.

However, this measurement provides important data that can be processed to make some conclusions about the controllers and the effectiveness of the new system. Figure 25 shows the energy balance during the driving cycle, where it was used the Fuel Economy Mode in all 30 min of test.

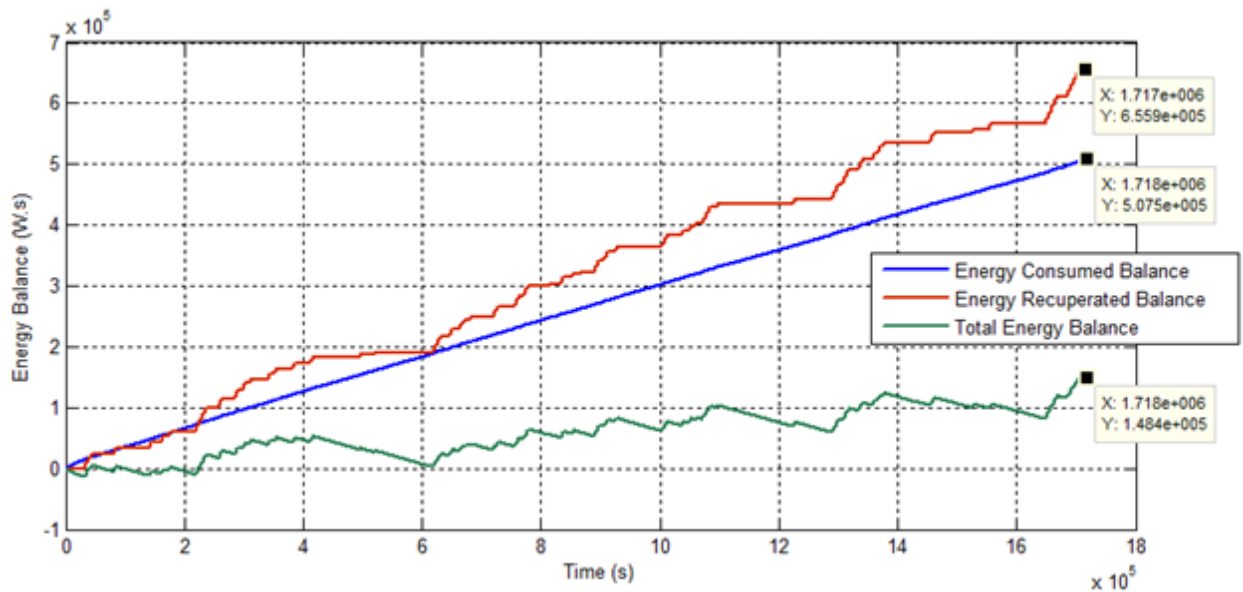

Figure 25: Energy balance on WLTP

- Energy used: - 507.5 kW.s;
- Energy recuperated: + 655.9 kW.s;
- Total energy balance: + 148.4 kW.s;

As a result from WLTP data, we can use FEM during all the cycle without any harm to the battery; instead, the recuperation events are so advantageous that the battery finishes this driving test with more State of Charge than in the start.

### 6.3 Starting Performance

Since the battery is the main source during vehicles start, the behavior during this task must be studied to verify the stability of the component and guarantee that the electronic system won't be damaged.

In case of Lead-Acid battery, the voltage dip when cranking vehicles is too drastic, demanding the integration of an additional DC/DC converter to stabilize it.

Figure 26 presents a start test with an AGM battery, where it is possible to see the voltage (blue lines) dropping down to 9 V (scale at right).

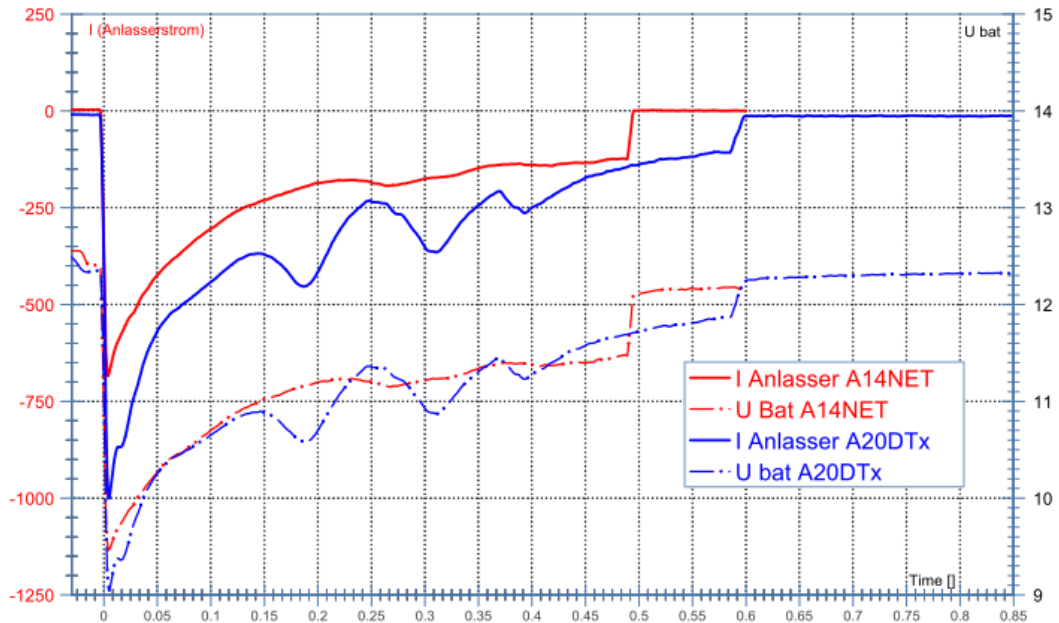

Figure 26: Lead-Acid voltage drop

Li-Ion batteries have shown better results during this kind of measurement (Figure 27). The voltage drop goes around 10.5V, which is very high and maybe for future researches it allows the removal of DC/DC device, reducing costs.

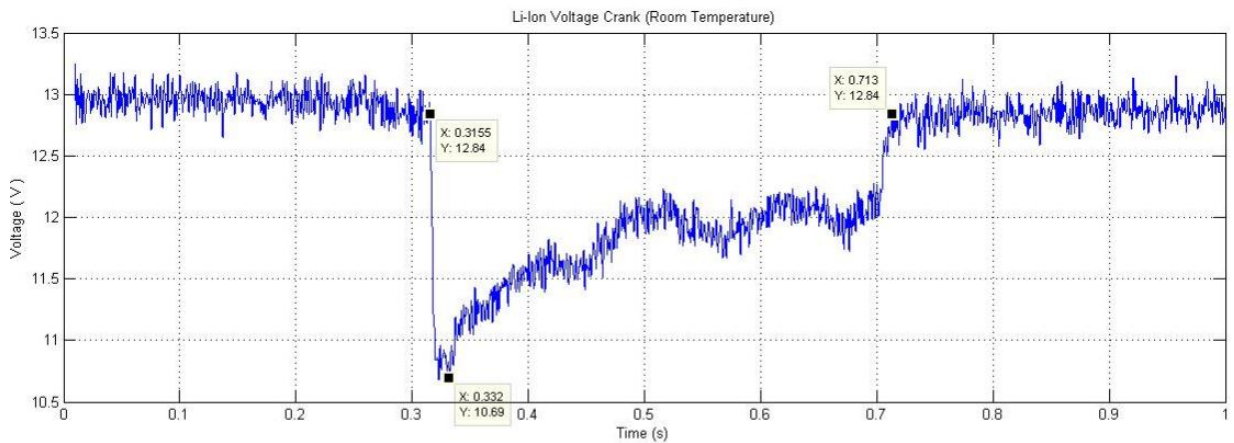

Figure 27: Lithium-Iron Phosphate voltage drop



## 6.4 Measurements to be done

Beyond all the analysis and validation tests realized, there are several extra measurements that must be performed with the new system to sustain future decisions about electric topologies.

These tests were not achieved because of the short internship time and long scheduling queues; however, they are very important and must be defined as future tasks. Some of them are:

- Cold cranking test at - 30 °C;
- Vibration tests during the crank;

Also, it is necessary to repeat all tests with different vehicle's engines, aged battery and different ranges of SoC.

## Chapter 7: Conclusion

The process of creating new technologies requires plenty of time and commitment, mostly inside a big company. Researches must be done to justify the company investments and changes should be carefully studied to avoid any direct damage. Moreover, Opel's resources are shared with hundreds of employees and consequently are much requested, which slow down the development.

Adapting the system to bear the Lithium-Iron Phosphate battery involved varied obstacles: acquiring the battery itself, installing the component in the vehicle, missing software licenses and malfunctioning intelligent battery sensors. As result alternative ways had to be taken to solve these problems.

Once with the battery equipped developing the controls turned to be an iterative process of creating and testing to monitor the efficiency of the solution, in each step adding new features to the strategy. Nevertheless, the control theory learned during the studying years proved to be very useful since the practical problems followed the same pattern than theoretical.

The Lithium-Iron Phosphate battery exhibits formidable results when adapted to the vehicle, bringing several advantages to real life driving and company's measurements.

Removing several operational modes (section 4.3.2) avoids the processing overload and releases the busy Body Control Module to work on different tasks quickly. Furthermore using the ECM to control the closed-loops is very helpful to speed up the responses.

Recuperation events are better used since the Li-Ion battery has capacity of bear all the current supplied, recovering about 4 times more energy than a Lead-Acid. Using the recuperation in association with the Fuel Economy mode saves a significant amount of fuel and can be used during long periods without harming the battery.

Table 1 (section 4.1) give us just a short overview of how good lithium-based components are in comparison to standard batteries. Just the weight factor is already a reason for the change in some cases and there are several other problems

justifying it. Some issues like environmental impact and regulation are being weighted as well.

Unfortunately this topology still is very expensive to mass production. So, small steps must be done to slowly include Li-Ion battery in the market, aiming to decrease the high costs.

## Chapter 8: References

- [1] Dirksen, S. n.d., *History of American Technology*, accessed 4 June 2014, <[http://web.bryant.edu/~ehu/h364proj/sprg\\_97/dirksen/electric.htm](http://web.bryant.edu/~ehu/h364proj/sprg_97/dirksen/electric.htm)>.
- [2] Dal Pont, M.P., 2013, *Charging Strategy with Lithium-ion Battery in 12V Vehicle Power Net*. Bachelor Thesis. UFSC: Brazil.
- [3] 2012, *Electrical Manual – 2013 Light Duty Full Size C/K Trucks*, accessed 6 June 2014, <[http://www.gmupfitter.com/publicat/2013\\_BB/2013\\_LD\\_FS\\_CKTruck\\_081512.pdf](http://www.gmupfitter.com/publicat/2013_BB/2013_LD_FS_CKTruck_081512.pdf)>.
- [4] Liberatti, B.J., 2013, *Smart Generator Control on Engine Efficiency Map*. Bachelor Thesis. UFSC: Brazil.
- [5] 2011, accessed 15 June 2014, <<http://www.advancedbatteryconcepts.com/markets.php>>.
- [6] *Lead Acid Battery History*, accessed 16 June 2014, <<http://lead-acid.com/lead-acid-battery-history.shtml>>.
- [7] Trojan Battery Company, 2013, *Comparing deep-cycle flooded batteries to VRLA batteries*, accessed 20 June 2014, <[http://www.trojanbatteryre.com/Tech\\_Support/ComparingFlood2VRLA.html](http://www.trojanbatteryre.com/Tech_Support/ComparingFlood2VRLA.html) >.
- [8] Ernst, C.S., Eckstein, L., Olschewski, I., 2012, *CO<sub>2</sub> reduction potential for passenger cars until 2020*. Aachen: Germany.
- [9] 2014, accessed 23 June 2014, *Developing vehicles to meet carbon emissions reduction targets*, <<http://www.paconsulting.com/our-thinking/developing-vehicles-to-meet-carbon-emissions-reduction-targets/>>.
- [10] Callaham, B., 2010, *Environmental Concerns With Sealed Lead-Acid Batteries*, <<http://www.livestrong.com/article/213685-environmental-concerns-with-sealed-lead-acid-batteries/>>.

## Appendix A – Lead-Acid Batteries: Flooded vs AGM

It is possible to divide Lead-Acid batteries in two distinct groups: Flooded and Valve-Regulated Lead-Acid (VRLA), this being subdivided in more two categories: Absorbed Glass Mat (AGM) and Gel [7].

Following it is presented some characteristics comparing the FLA and AGM:

<p style="text-align: center;">Flooded Advantages:</p> <ul style="list-style-type: none"> <li>•Lower cost.</li> <li>•Longer cycling capacity.</li> <li>•Can be maintained simply by addition of distilled water.</li> <li>•High discharge rate capability.</li> <li>•Perform better in hot climates. (&gt;32 °C)</li> <li>•More available worldwide.</li> <li>•Perform better with low SoC.</li> </ul>	<p style="text-align: center;">AGM Advantages:</p> <ul style="list-style-type: none"> <li>•Wider temperature range FLA batteries.</li> <li>•Slowest self-discharge rate between Lead-Acid batteries.</li> <li>•Best shock/vibration resistance between Lead-Acid batteries.</li> <li>•The best Lead-Acid battery for high power applications.</li> </ul>
<p style="text-align: center;">Flooded Disadvantages:</p> <ul style="list-style-type: none"> <li>•Periodic maintenance required.</li> <li>•Can only be used in an upright position.</li> <li>•Produce gas (oxygen and hydrogen) when charged.</li> <li>•May emit acid spray if overcharged.</li> <li>•Require ventilation.</li> <li>•Higher self-discharge rate than deep-cycle VRLA batteries.</li> <li>•Cannot be shipped by air.</li> <li>•Cannot be used nearby electrical of flammable components.</li> </ul>	<p style="text-align: center;">AGM Disadvantages:</p> <ul style="list-style-type: none"> <li>•Don't perform as well as FLA or Gel batteries for systems that require regular deep discharge. (less than 80% SoC)</li> </ul>

## Appendix B – Test Cycles<sup>11</sup>

### WLTP Cycle:

The Worldwide Harmonized Light Vehicle Test Procedures is a cycle test created to be more realistic with the real life drive, presenting two speed profiles: urban and highway; presenting an oscillatory speed, as showed in the figure below.

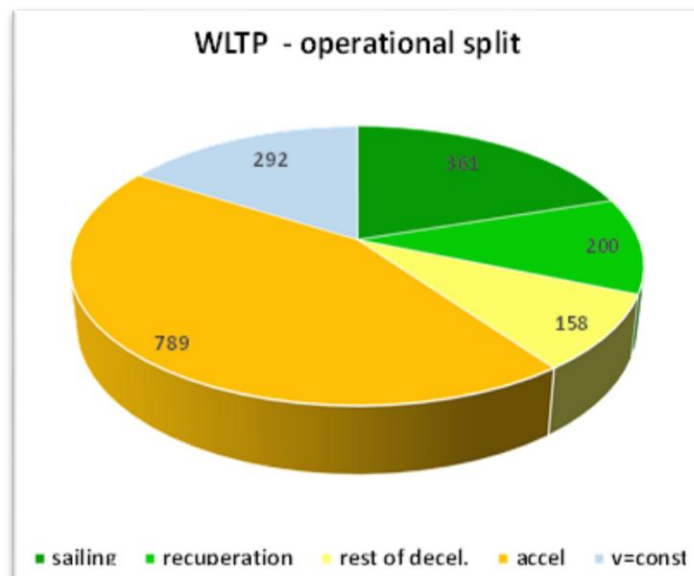
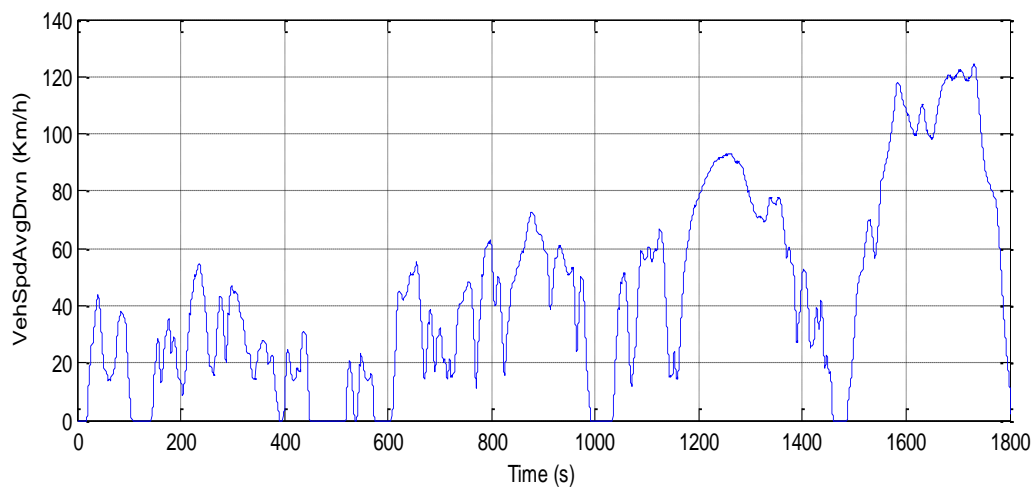

<sup>11</sup> Fragment removed from Appendix A in reference [4]

## WLTP Measurement:

